

KPM10 Three-phase Multifunction Power Meter Instructions V2.3



Danger and Warning

- The device may only be installed by professionals. Caused any malfunction due to not follow the instructions in this manual, Manufacturers will not bear any responsibility.
 - Electric shock burning and explosion**
 - Devices can only be installed and maintained by qualified staff.
 - Before any operation, the device should be isolated from the voltage input and power supply, and short circuit the secondary winding of all current transformers.
 - Verify if the device is live before operation.
 - All mechanical parts and covers should be restored in place before the device is energized.
 - Device in use should be provided with the correct voltage.
- Not paying attention to these precautions may cause serious injury.**

1.4 Mechanical properties

Vibration response: IEC255-21-1:1998, level 1
 Vibration durability: IEC255-21-1:1998, level 1
 Impact response: IEC 255-21-2, level 1
 Impact durability: IEC 255-21-2, level 1
 Collision: IEC 255-21-2, level 1

1.5 EMC performance

Electrostatic discharge immunity: IEC61000-4-4, level 4
 Fast pulse group immunity: IEC61000-4-5, level 4
 Surge immunity: IEC61000-4-2, level 4
 Power frequency magnetic field immunity: IEC61000-4-8, level 4

2. Installation and wiring

2.1 Shape and hole size

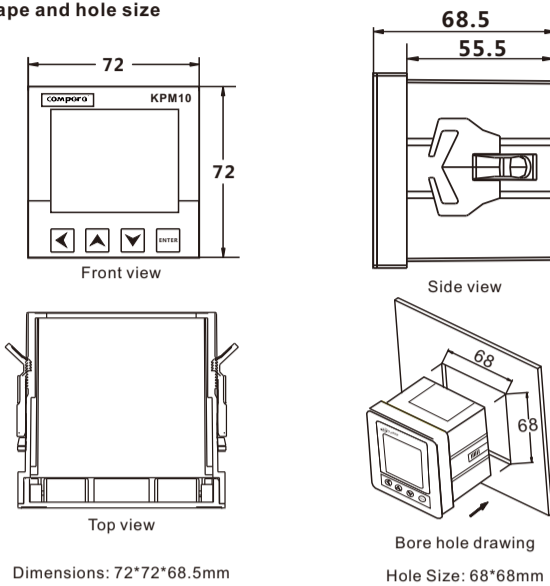

2.2 Terminal wiring

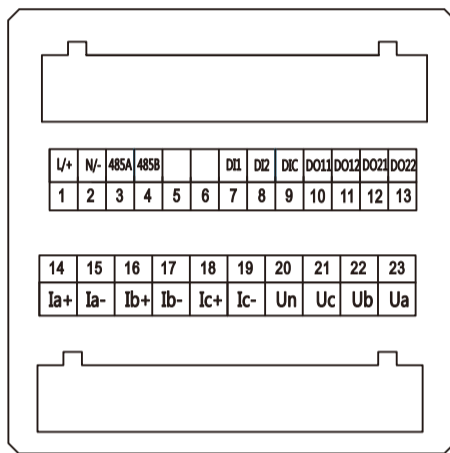

1. Technical Parameters

1.1 Environmental conditions

Operating temperature: -25°C ~ +70°C Storage temperature: -30°C ~ +75°C
 Relative humidity: 5% ~ 95% No condensation
 Altitude : 3000 meters below

1.2 Rated parameters

Device working power supply: AC 85~265VAC , DC 80~300VDC
 Rated AC data Phase voltage: 220V
 AC current : 5A
 Frequency : power frequency 50Hz
 Switch input: Internal 24VDC DC power supply ,40ms debounce time
 Switch output : Small high power relays ,Contact capacity250VAC/5A,30VDC/5A
 Power consumption AC voltage loop: < 0.5VA / phase (rated)
 AC current loop: < 0.75VA / phase (5A)
 < 0.25VA / phase (1A)
 Device power supply circuit: <3VA
 Overload capacity AC voltage loop :
 1.2 times the rated voltage Continuous operation
 2 times the rated voltage , Allow 10S
 AC current loop:
 1.2 times the rated voltage,Continuous operation
 20 times the rated voltage ,Allow 1S

Precision index

Parameter	Accuracy	Resolution	Parameter	Accuracy	Resolution
Voltage	±0.2%	0.01V	Power factor	±0.5%	0.01
Current	±0.2%	0.01A	Active energy	0.5S	0.1kWh
Active power	±0.5%	0.1W	Reactive	±2.0%	0.1kvarh
Reactive power	±2.0%	0.1var	Frequency	±0.02	0.01Hz
Apparent power	±0.5%	0.1VA			

1.3 Electrical insulation performance

Power frequency withstand voltage: In line with GB / T13729-2002 provisions, Power frequency voltage 2KV,Insulation resistance 1 minute.
 Insulation resistance: In line with GB / T13729-2002 provisions, Insulation resistance ≥50MΩ
 Impulse voltage: In line with GB / T13729-2002 provisions, can bear the impact of 1.2 / 50US, 5KV peak standard lightning.

3. Function Description

3.1 Power symbol

KPM10 provides bidirectional power calculation, power and power factor polarity as shown in the figure.

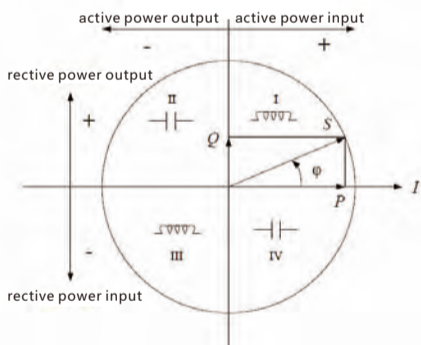

3.2 Power measurement

KPM10 bidirectional recording power sum of active and reactive energy, and the negative bi-directional power, voltage and current negative net power.

3.3 Switch input

KPM10 provide 2-channel switch input, used to detect the circuit breaker position signal, switch position signal and other status information. DC24V power supply is provided inside the equipment, when the scene requires a binary input function, external access passive contact signal, when the external contact closed, the corresponding switch input state is also turned on.

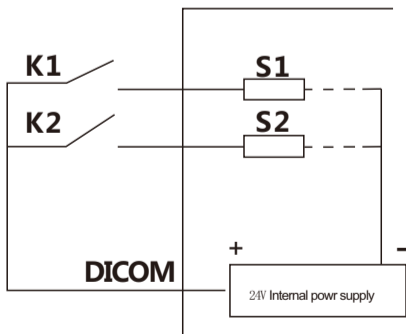

3.4 Relay output

KPM10 provides two relay actions, the user to identify the relay is in the remote control or control alarm. Different control mode, the relay action mode is different.

Remote control: Relay through the communication with the command to control by the PC or PLC.

Limit alarm control: The relay is controlled by an electrical parameter inside the meter as a response to a set point control alarm condition.

The two relays action mode as follows Remote control: By accepting a PC or PLC command, relay closes. The relay status will remain on still the PC or the PLC will issue a release command, or the meter power loss.

Limit alarm control: When the alarm signal of the trigger relay is generated, relay action.Until the alarm condition of all trigger relays disappears or the meter is out of order,the relay is released. If the meter recovers the power and the alarm condition persists, the relay will act again.

4. Operating instructions

4.1.Interface display

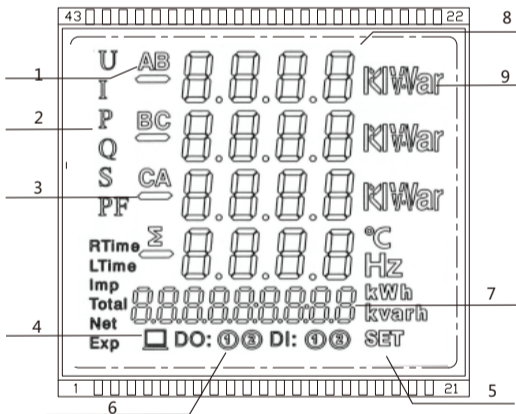

index	Display content	Detailed Description
1	Phase sequence indication	Indicated A, B, C-phase value, AB, BC, CA three-line value and Σ three-phase sum, such as three-phase total active power, total reactive power, total apparent power and so on, N represents zero line
2	Measurement data type	Identifies the parameter name displayed in the current measurement data display area in alphabetical form : Voltage is "U", current is "I", active power is "P", reactive power is "Q", apparent power is "S", power factor is "PF", frequency is "F", demand is "DM", harmonic is "HD", unbalance is "UNB", maximum is "Max", minimum is "Min", temperature is "T", meter operation time is "RTime", load time is "LTime", two months ago is "B Mon", last month is "L Mon", this month is "T Mon", the day before yesterday is "B Day", yesterday is "LDay", today is "T Day"
3	negative sign	Displayed when the measured data is negative
4	Communication indication	If two small computers all faded, that there is no communication message; two small computers all show that the communication
5	Set	When the set light is on, it indicates that it has entered the parameter setting state.
6	Relay output status	When there is a digital display, it indicates that the corresponding loop relay is closed.
7	Power and time display area	Display a variety of electrical measurement data, real-time clock, parameter settings, such as data settings.
8	Measurement data display area	Display the main measurement data: voltage, current, power, power factor, frequency, temperature, harmonic data, demand, maximum, minimum, parameter setting data, etc.
9	Electrical parameter unit symbol	voltage : V , kV ; current : A , kA ; active power : W , kW , MW ; reactive powervar , kvar , Mvar , Apparent power : VA , kVA , MVA ; frequency : Hz ; active electricity : kWh ; reactive electricity : kvarh ; apparent electricity : kVAh percentage : % ; etc.

4.2 Operation display

There are four touch buttons on the front panel,the four keys are marked as key left ◀ ,key up ▲ ,key down ▼ , key enter ENTER .Through the operation of four keys can be achieved in different measurement data display and parameter settings.



Index	Mark	Define	Index	Mark	Define
1	L/+	positive	13	DO22	Relay output
2	N/-	negative	14	Ia+	A-phase current into the line
3	485A	RS485 positive	15	Ia-	A-phase current outlet
4	485B	RS485 negative	16	Ib+	B-phase current into the line
5			17	Ib-	B-phase current outlet
6			18	Ic+	C-phase current into the line
7	DI1	Switch input 1	19	Ic-	C-phase current outlet
8	DI2	Switch input 2	20	Un	Voltage neutral line
9	DIC	Switch terminal	21	Uc	Phase C voltage
10	DO11	Relay output 1 forward	22	Ub	Phase B voltage
11	DO12	Relay output 1 negative	23	Ua	Phase A voltage
12	DO21	Relay output 2 forward			

2.3 Typical wiring

KPM10 provides star system and triangular system wiring mode, the common wiring mode is as follows:

2.3.1 Star system wiring mode

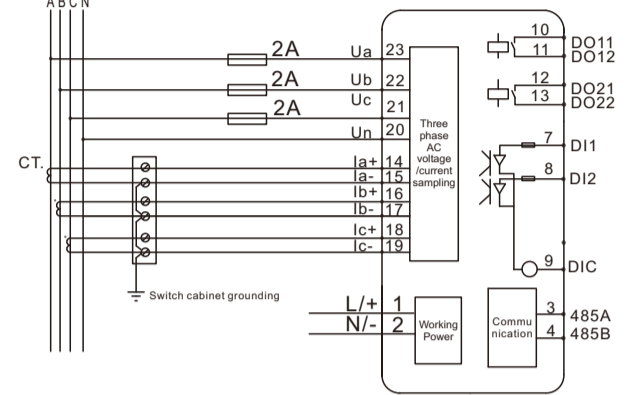

Four lines star system: Direct wiring without voltage transformer(PT) (The device is set to 3Ln3Ct)

2.3.2 Triangular system wiring mode

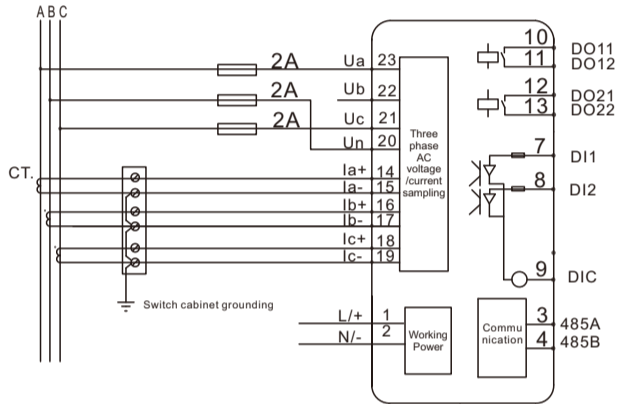

Buttonname	Functional description
Left key	Switch the items of electrical parameter in the electrical measurement interface; in the parameter setting interface state as move parameter bit key.
Up key	press the up key to increase the value of the modified bit in the parameter setting state.
down key	Press the down key to decrease the value of the modified bit.
ENTER	Enter the programming state, in the parameter setting state is used to enter the menu, programming parameters and confirmation.
Left key+Down key	Enter or exit the harmonic parameters query interface.
Left key+Up key	Exit setting data interface.

In the electrical parameter measurement interface,press up key or down key to display real-time measurement data in turn, as shown.Phase voltage ,phase active power,reactive power,apparent power and power factor won't be displayed in the mode of 2LL2CT and 2LL3CT.

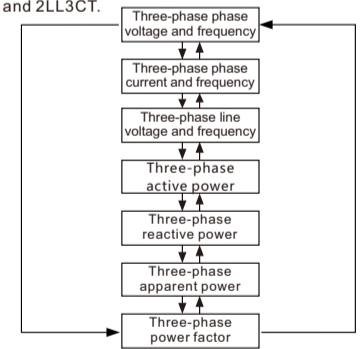

Electrical parameter query interface

In the electrical parameter measurement interface, "Hd_" is on, you can use the down key or use the up key to see the three-phase voltage and current harmonic total distortion rate and 2 ~ 31 harmonic content. The upper left corner shows "U", for this parameter indicates a three-phase harmonic voltage, when display "I", for this parameter indicates a three-phase harmonic current, the first three lines show the total harmonic distortion and fractional harmonic content, the fourth line represents the current harmonic data type, the total harmonic distortion is displayed when "THd" is displayed, when "HR" is displayed, the data indicates the fractional harmonic content, 2 ~ 31 that the corresponding number of harmonics.

Press the left key in the electrical parameter measurement interface can enter power and time query interface.Continuous press will display the following interface.

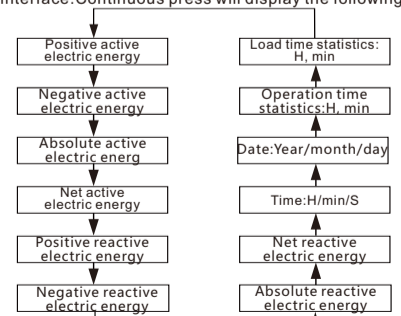

Power and time query interface

Press the ENTER key to enter the password input interface in the electrical parameter measurement interface, the default password 6666, press the ENTER key after the password input is confirmed. If the input correctly enters the parameter setting interface, if the input error returns to the display interface of the measurement parameters. Press the ENTER key to enter the parameter size of the modified state, and accompanied by the modification of the characters flashing, after the change is completed, press the ENTER key to confirm the parameters of the parameters can be changed, You can modify the next parameter, you can also leave the left side of the parameters of the modified state, return to the measurement interface.

When the user in the modified state of the parameters within 60 seconds without key operation will automatically return to the electrical parameters of the measurement display interface.

Factory default value

parameter	Display	Default	implication
Password protection	PASS	6666	Used to protect non-staff to modify
Wiring method	SYSS	3Ln3CT	Three-phase four-wire system, 2LL2CT and 2LL3CT Three-phase three-wire system
Voltage ratio	Pt_U	1	Voltage transformer ratio(1~9999)
current	Ct_I	1	Current transformer ratio(1~9999)
communication address	Adr	1	The address of the meter when the network is in communication 1~247
Baud rate	bAUd	9600	Communication Baud rate address 1200~19200
Data forma	dAtA	81N	Data frame format : 8 data bits, a parity bit
backlight	BLt	1	units: minute ; If set to 0, the backlight will never go out; set to other values, the last time after the delay set the time off.
System data	dAtE	Current date	Such as : 2012.05.08
System time	tinE	Current time	Such as : 09:35:20
Electric energy clear	cLrEny	Cleared	Used to clear the energy parameters.
Firmware	VEr		The firmware version and date of the instrument

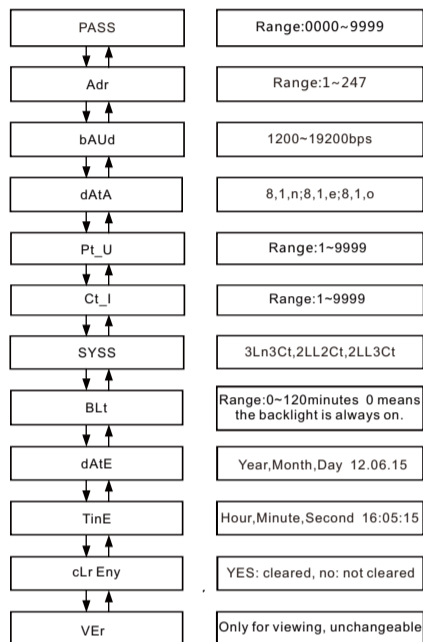

Set interface

5. communication

KPM10 three-phase multifunction power meter provides MODBUS-RTU communication protocol, a start, 8-bit data bits, 1/0 parity, 1/2 stop bits, each byte length of 11 bits.

Supported baud rates: 1200, 2400, 4800, 9600, 19200bps.

Factory default communication parameters: 9600, no parity, 1 stop bit.

RTU mode format for each byte:

1 start bit + 8 data bits + 1 parity bit + 1 stop bit

The format of the data frame is as follows:

Address field + Command field + Data field + CRC check area

Note: The minimum frame communication interval is 100ms.

Supported function codes			
DEC	HEX	definition	Operation description
01	0x01	Read relay output	Read one or more relay outputs
02	0x02	Read switch input	Read one or more switch input
03	0x03	Read register data	Read the value of one or more registers
05	0x05	Write a single relay output	Control all the way to close or disconnect the relay
16	0x10	Write multiple registers	Write multiple register data at a time

5.1 Relay output control and status read

This area stores the relay status. The user can read the current status using the Modbus protocol 01H function code and use the function code 05H to control the output.

Address	Parameter	Numerical range	Data type	Read-write property
0000H	Relay1(DO1)	1=ON,0=OFF	Bit	R/W

5.1.1 Read relay output status (function code 01H)

Addr	Fun	Start Reg hi	Start Reg lo	Reg Num hi	Reg Num lo	CRC16 hi	CRC16 lo
01H	01H	00H	00H	00H	01H	xxH	xxH

Response Data Frame: The slave responds to the host's data frame. (1 = ON, 0 = OFF), the lowest bit of the first byte is one of the lowest bits of the first byte. The first bit of the first byte is the lowest byte of the first byte. Address the relay state value, the rest of the order to the high order, useless bits filled with 0.

Read the contents of the digital output status response example.

Addr	Fun	Byte count	Data	CRC16 hi	CRC16 lo
01H	01H	01H	01H	90H	48H

Data byte content (Relay 1 is closed)

Bit7	Bit 6	Bit 5	Bit 4	Bit 3	Bit 2	Bit 1	Bit 0
0	0	0	0	0	0	0	1

5.1.2 Relay control (function code 05H)

Note that the control relay 0x00000 is the relay separated, 0 x FF00 means relay closed.

Request data frame

Addr	Fun	DO addr hi	DO addr lo	Value hi	Value lo	CRC16 hi	CRC16 lo
01H	05H	xx	xx	FFH	00H	xxH	xxH

Response data frame

Addr	Fun	DO addr hi	DO addr lo	Value hi	Value lo	CRC16 hi	CRC16 lo
01H	05H	xx	xx	FFH	00H	xxH	xxH

5.2 Read switch input status (function code 02H)

Query data frame: This function allows the user to obtain the status of the binary input DI ON / OFF (1 = ON, 0 = OFF). In addition to the slave address and the function field, the data frame needs to be included in the data field. The initial address and the number of DIs to be read.

The address of DI in KPM10 starts at 0000H (DI1 = 0000H, DI2 = 0001H ... and so on).

The binary input terminals DI1 to DI2 correspond to Bit0 to Bit1, respectively. The following example shows the state of the DI1 to DI2 read from the slave address 01

Addr	Fun	DI start reg hi	DI start reg lo	DI num hi	DI num lo	CRC16 hi	CRC16 lo
01H	02H	00H	00H	00H	04H	xx	xx

Response Number of Frames: The response contains the slave address, function code, number of data, packet and CRC check, each bit in the packet occupies one bit (1 = ON, 0 = OFF), the least significant bit of the first byte is the addressed DI1 value, the other is followed by the higher order, and the useless bit is filled with 0.

The following table shows an example of a read-through input (DI1 = ON, DI2 = ON) response.

Addr	Fun	Byte count	Data	CRC16 hi	CRC16 lo
01H	02H	02	0101	00	01

6. Common malfunction Analysis

- Nothing is displayed after the unit is powered on
 - Check if the supply voltage and other wiring are correct, also the supply voltage should be within the operating range
 - Turn off the device and the host computer, and then reboot
- The device is not working properly after power on
 - Turn off the device and the host computer, and then reboot
- Voltage or current readings incorrect
 - Check if the wiring mode setting matches the actual wiring mode
 - Check whether the voltage transformer (PT) and current transformer (CT) ratio are set correctly
 - Check if GND is grounded properly
 - Check if the shield is grounded
 - Check if the voltage transformer (PT) and current transformer (CT) are intact
- The power or power factor reading is incorrect, but the voltage and current readings are correct
 - Compare the voltage and current input of the actual wiring and wiring diagram, and check if the phase relationship is correct
- RS-485 communication is not working properly
 - Check whether the communication baud rate, ID and communication protocol settings of the host computer are consistent with the meter
 - Please check the data bits, stop bits, parity settings and the host computer is consistent
 - Check if the RS-232 / RS-485 converter is working properly
 - Check if there are the problems in the entire communications network lines (Such as short circuit, open circuit, grounding, if the shield is properly grounded at one end, etc.)
 - Turn off the device and the host computer, and then reboot
 - If the communication line is longer, it is recommended to parallel connect a 100~200Ω matching resistors at the end of the communication line

Note: If there are any unsolved problems, please contact our company's after-sales service department.

7 Contact details

Henan Compere Smart Technology CO., LTD.

Telephone:+86-371-86181681

Fax:+86-371-67890037

Web:www.comperepower.com

Address:Unit 1, Building 38, Liandong U Valley, No. 352 Lianhua Street, High-tech Zone, Zhengzhou, China

The final interpretation of this manual is owned by Henan Compere Smart Technology Co.,Ltd.