

2 Technical Parameters

2.1 Environmental Conditions
Working temperature: -10℃+55℃
Relative humidity: 5%~95% non-condensing
Storage temperature: -20℃+75℃
Altitude: Below 3000 meters

2.2 Rated Parameters
Input voltage: Rated 220V
Input current: 0.2-1 (60A)
Power consumption: Power consumption < 0.5VA
Overload capacity:
AC voltage loop: 1.2 times rated voltage, continuous work
2 times rated voltage, allow 10s
AC current loop: 1.2 times rated current, continuous work
20 times rated current, allow 1s

2.3 Measurement Accuracy Index

Parameters	Accuracy	Parameters	Accuracy
U	±0.2%	PF	±0.5%
I	±0.2%	kWh	0.5s/B
P	±0.5%	kVar	Class 2
Q	±2%	F	±0.02

2.4 Electrical insulation Performance
Medium strength:
Comply with GB/T13729-2002 regulations, Power frequency voltage 2KV, me 1 minute
Insulation resistance:
Comply with GB/T13729-2002 regulations, 500V megger test, insula on resistance not less than 50MQ
Impulse voltage:
Comply with GB/T13729-2002 regulations, Withstand the impact of 1.2/50US peak 5KV standard lightning wave

2.5 Mechanical properties
Vibration response: IEC255-21-1, level 1
Vibration durability: IEC255-21-1, level 1
Impact response: IEC 255-21-2, level 1
Impact durability: IEC 255-21-2, level 1
Collision: IEC 255-21-2, level 1

2.6 EMC performance
Electrostatic discharge immunity : IEC61000-4-2, level 4
Fast pulse group immunity: IEC61000-4-4, level 4
Surge immunity : IEC61000-4-5, level 4
Power frequency magnetic field immunity : IEC61000-4-8, level 4

3. Installation and Wiring

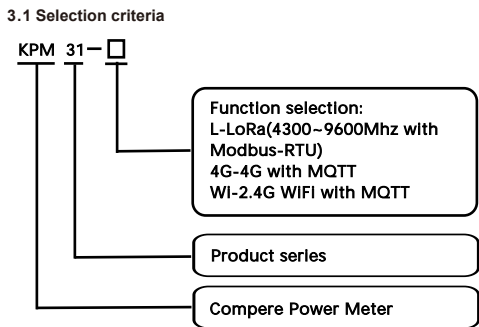

Supported baud rate: 1200, 2400, 4800, 9600 (bps).
Factory default communication parameters: 9600bps, even parity
The format of each byte in RTU mode:
1 start bit + 8 data bits + 1 parity bit + 1 stop bit
The format of the data frame is as follows:
Address field + command field + data field + CRC check field

Function code	HEX	Definition	Description
01	0X01	Read relay output	Read relay output state
03	0X03	Read register data	Read one or more registers' value
05	0X05	Read single relay output	Control one relay to close or open
16	0X10	Write multiple register	Write multiple register once

6.1 Read and write system parameters
This area stores system parameters related to device work, including communication, password and other parameters, which can be read by Modbus-RTU protocol 03H function code, or set using 10H function code.

Addr	Parameter	Description	Data type
0000H	Protection password	0-9999	Word
0001H	Communication address	ModBus address:1~247	Word
0002H	Baud rate	Baud rate(BIT0~BIT7): 0:1200,1:2400,2:4800,3:9600 Check bit(BIT8~BIT15): 0:Even, 1:Odd,2:None	Word
000CH	Clear energy	Command 0x55AA, clear energy immediately Command 0x55CC, clear prepaid energy immediately	Word
000DH	NULL		Word
000EH	Prepaid	Prepaid energy	Word
0012H	SN Serial number (Read only)	(4bytes Float type) Continuous 14 bytes First 13bytes is serial number	Word
0018H	Remote forced power on/off	Command 0xAADD+Word (Forced power off time unit: min) Remote forced power off Command 0xBDDD+Word (Forced power off time unit: min) Remote forced power on	Word
001DH	Load Control Duration	0-65535(Unit-second)	Word
001EH	Local/Remote control	Command 0xDD11: local control Command 0xDD22: remote control	Word
0020H	Credit value	Credit value (4bytes float type)	Word
0023H	Time	Date and time(6bytes)	Word
0026H	Load threshold	0-65535	Word

⚠ Danger and Warning

- The device can only be installed by professionals.
- The manufacturer will not take any responsibility for failures caused by not following the instruction.

⚡ Electric shock, burning and explosion

- Device should only be installed and maintained by qualified personnel.
- Before carrying out any operation on the device, isolate the voltage input and power supply, and short-circuit the secondary windings of all current transformers.
- Confirm that the voltage has been cut off before operation.
- All mechanical parts and covers, etc. should be restored to their original positions before the device is powered up.
- The device should be supplied with the correct rated voltage during use.

1. Overview
1.1. Function introduction
KPM31 is designed with advanced microprocessor and digital signal processing technology. It integrates comprehensive single phase power measurement, display, energy accumulation, and network communication. It has strong anti-interference ability and can still work stable in situations with severe electromagnetic interference.

1.2 Applications

- Measure and monitor electric energy parameters in the distribution system
- Energy efficiency management system
- Statistical analysis of internal power consumption and basis for charging statistics
- Automatic meter reading system for electric energy measurement
- Intelligent power distribution management system

1.3 Features

- Measure single-phase voltage, current, active power, reactive power, apparent power, active / reactive energy, power factor, frequency, etc..
- 0.5S level bidirectional four-quadrant power statistics.
- Multi-rate energy metering, 4 time zones, 8 time periods, 4 rates.
- 1 * RS485 port with Modbus-RTU.
- 2.4G WIFI/4G with MQTT. Or LoRa with Modbus-RTU.
- Prepaid function, load control, self & remote control.
- Class 0.5S bidirectional four-quadrant energy statistics.
- 12-month historical energy statistics.
- Rated current 0.2-1 (60)A, rated voltage 220VAC.
- 1 channel passive optocoupler collector active pulse output.
- Segment code LCD "7+1" bit display, good visual under strong light and large viewing angle environment.
- 35mm standard rail installation.
- Multi rate electric energy statistics: 4 kinds of rates, 2 sets of time zone tables, 2 sets of time interval tables.

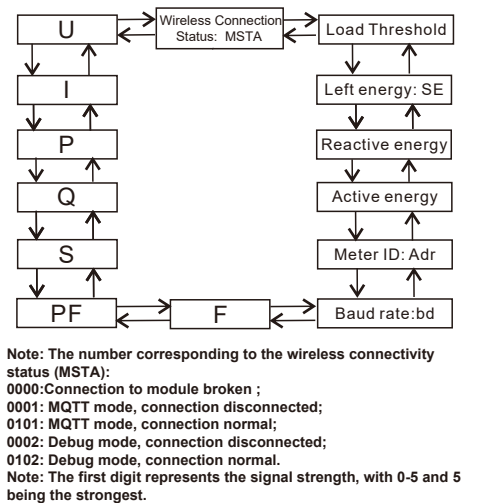

5.4 Parameter setting interface display
In the parameter measurement page, long press the "ENTER" key for 3s to enter the password input page, the default password: 6666. Input the correct password, short press the "ENTER" key to enter the parameter setting page. Then short press the "down" key to select the parameter to be set. Short press the "ENTER" key and the 1st bit from left of the set value starts to flash, short press the "left" key to select to modify the bit, short press the "down" key to increase the modified bit value. After the modification is completed, press the "ENTER" key to confirm. In the setting interface, if no key is pressed for 30s, it will return to the measurement display screen. Or long press the "left" key to return.

The parameter setting structure menu is as follows:

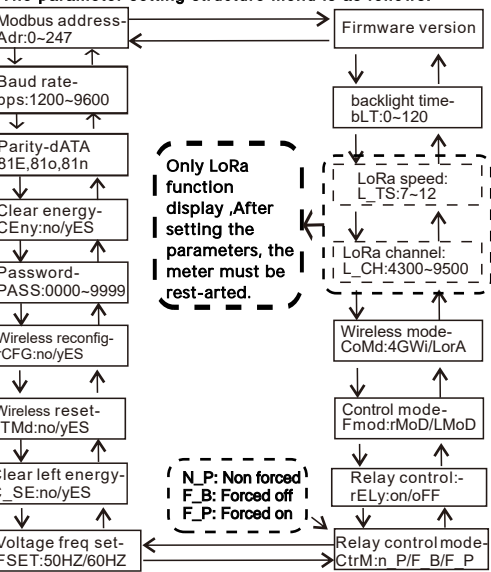

6 Communication
KPM31 provides MODBUS-RTU communication protocol, 1 start bit, 8 data bits, 1 parity bit, 1 stop bit, each byte length is 11 bits.

3.2 Size and appearance (Unit:mm)

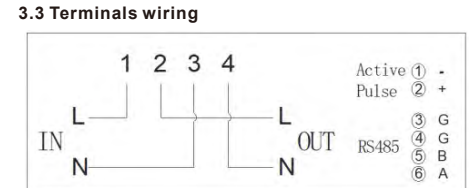
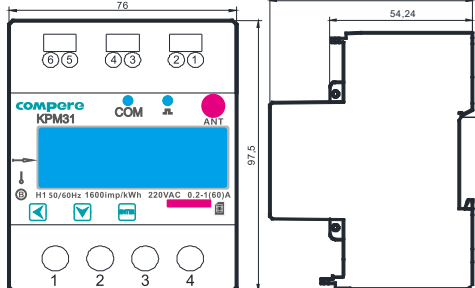

The wiring terminals are shown as follows:

Power side terminal definition

No.	Mark	Definition
1	L in	AC power terminal L, incoming side
2	L out	AC power terminal L, appearing side
3	N in	AC power terminal N, incoming side
4	N out	AC power terminal N, outgoing side

Function side terminal definition

No.	Mark	Definition
①	-	Pulse output -
②	+	Pulse output +
③	G	RS485 ground
④	G	RS485 ground
⑤	B	RS485B
⑥	A	RS485A

4 Function description

4.1 Electric energy measurement
KPM31 records the historical total active power, total reactive power, import/export active and reactive power, consumption of active and reactive power for last 12 month (Settled and stored at 0:00 on the 1st of each month).
KPM31 also provides multi-rate electric energy, providing 4 rates of sharp, peak, flat and valley, 8 periods can be set in one day. It can record total active/reactive power consumption at 4 rates for 12 months.
For example, the daily electricity measurement is divided into 5 time periods:

Time Slot	Start Time	Rate
1#	6:00	1
2#	10:00	2
3#	12:00	1
4#	15:00	3
5#	23:00	4

1# segment starts from 6 o'clock to 10 o'clock, billing segment is 1.
2# segment starts from 10 o'clock to 12 o'clock, billing segment is 2.
And so on, 5# period starts from 24 o'clock to 6 o'clock the next day, and the billing segment is 4.
The electricity kWh of the same rate is calculated in combination.

6.2 Basic Measuring Parameters

Basic measurement area, mainly measuring basic voltage, current, power, power factor, etc., The parameters in this area are all real-time measurement parameters, which are read using Modbus-RTU protocol 03H function code and are read-only data. The data format is floating point data. The data in this area is real-time data for primary side.

Addr	Parameter	Data format	Unit
0030H	U	Float	V
0032H	I	Float	A
0034H	P	Float	W
0036H	Q	Float	var
0038H	S	Float	VA
003AH	PF	Float	
003CH	F	Float	Hz
0070H	Apparent demand	Float	VA

6.3 Multi-rate electricity

Each parameter in this area is the accumulated amount of electric energy, which is the data of the primary side, which can be read by the Modbus-RTU 03H function code.

Addr	Parameter	Data format	Unit
0080H	Total active energy	Float	kWh
0082H	Import active energy	Float	kWh
0084H	Export active energy	Float	kWh
0086H	Total reactive energy	Float	kvarh
0088H	Import reactive energy	Float	kvarh
008AH	Export reactive energy	Float	kvarh
008CH	Total sharp active energy	Float	kWh
008EH	Total peak active energy	Float	kWh
0090H	Total flat active energy	Float	kWh
0092H	Total valley active energy	Float	kWh
0094H	Total sharp reactive energy	Float	kvarh
0096H	Total peak reactive energy	Float	kvarh
0098H	Total flat reactive energy	Float	kvarh
009AH	Total valley reactive energy	Float	kvarh
009CH	Total combined active energy for this month	Float	kWh
009EH	Total combined active energy of the previous 1 settlement day	Float	kWh
00A0H	Total combined active energy of the previous 2 settlement day	Float	kWh
00A2H	Total combined active energy of the previous 3 settlement day	Float	kWh
00A4H	Total combined active energy of the previous 4 settlement day	Float	kWh
00A6H	Total combined active energy of the previous 5 settlement day	Float	kWh
00A8H	Total combined active energy of the previous 6 settlement day	Float	kWh
00AAH	Total combined active energy of the previous 7 settlement day	Float	kWh
00ACH	Total combined active energy of the previous 8 settlement day	Float	kWh
00AEH	Total combined active energy of the previous 9 settlement day	Float	kWh
00B0H	Total combined active energy of the previous 10 settlement day	Float	kWh
00B2H	Total combined active energy of the previous 11 settlement day	Float	kWh
00B4H	Total combined active energy of the previous 12 settlement day	Float	kWh
00B6H	Total combined active energy for this month	Float	kvarh
00B8H	Total combined active energy of the previous 1 settlement day	Float	kvarh
00BAH	Total combined active energy of the previous 2 settlement day	Float	kvarh
00BCH	Total combined active energy of the previous 3 settlement day	Float	kvarh
00BEH	Total combined active energy of the previous 4 settlement day	Float	kvarh
00C0H	Total combined active energy of the previous 5 settlement day	Float	kvarh
00C2H	Total combined active energy of the previous 6 settlement day	Float	kvarh

4.2 Pulse output

- KPM31 provides active/reactive energy measurement, active energy pulse output function, adopts the output of the optocoupler open collector, the method of energy accuracy inspection refers to the national measurement regulation.
- Metrology Regulations: Pulse Error Comparison Method for Standard Meters
- Electrical characteristics: open collector voltage VCC≤48V, Current Iz≤50mA;
- Pulse constant: 1600 imp/kWh

5 Operating Instructions

5.1 Display
There are 3 operation buttons on the front, which are marked from left to right as left, down, and ENTER. Users can view different measurement data through the operation of the keys.

Key name	Function description
◀ (Left)	Switch the display interface of basic measurement parameters, and turn the page up. Press and hold to enter the parameter design interface, and in the parameter setting state, it is used to modify the position of the value to be modified.
▼ (Down)	Switch the display interface of basic measurement parameters and turn page down. In the parameter setting state, it is used to increase the value of the bit to be modified.
ENTER (Confirmation)	In the display state, press it once to display the current time, and press it twice to exit the display. In the parameter setting state, it is used to select and modify the parameters and confirm the modification. Press and hold the confirmation password to enter the parameter setting mode.

5.2 Power energy measurement interface display
After the device is powered on and working, the main interface is displayed as the power energy measurement interface, and the measurement interface can be switched by pressing the left key and the down key, and the structure of the measurement interface menu is as follows:

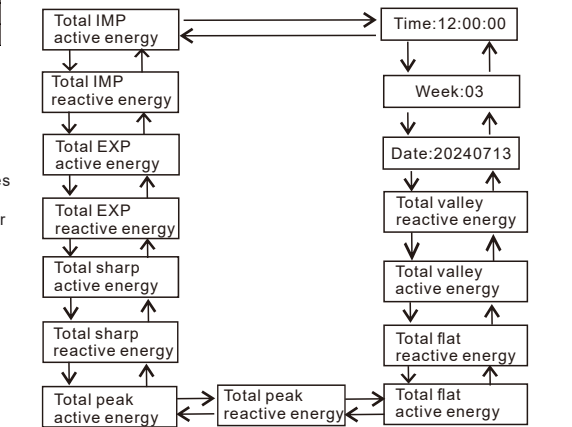

5.3 General parameter measurement interface display

Shortly press ENTER key in the electric energy measurement interface to enter the general parameter measurement interface, by pressing the left key and the down key you can switch to the measurement interface, which displays the interface structure menu as follows.

00C4H	Total combined active energy of the previous 7 settlement day	Float	kvarh
00C6H	Total combined active energy of the previous 8 settlement day	Float	kvarh
00C8H	Total combined active energy of the previous 9 settlement day	Float	kvarh
00CAH	Total combined active energy of the previous 10 settlement day	Float	kvarh
00CCH	Total combined active energy of the previous 11 settlement day	Float	kvarh
00CEH	Total combined active energy of the previous 12 settlement day	Float	kvarh
00D0H	Sharp active energy for this month	Float	kWh
00D2H	Sharp active energy of the previous 1 settlement day	Float	kWh
00D4H	Sharp active energy of the previous 2 settlement day	Float	kWh
00D6H	Sharp active energy of the previous 3 settlement day	Float	kWh
00D8H	Sharp active energy of the previous 4 settlement day	Float	kWh
00DAH	Sharp active energy of the previous 5 settlement day	Float	kWh
00DAH	Sharp active energy of the previous 6 settlement day	Float	kWh
00DEH	Sharp active energy of the previous 7 settlement day	Float	kWh
00E0H	Sharp active energy of the previous 8 settlement day	Float	kWh
00E2H	Sharp active energy of the previous 9 settlement day	Float	kWh
00E4H	Sharp active energy of the previous 10 settlement day	Float	kWh
00E6H	Sharp active energy of the previous 11 settlement day	Float	kWh
00E8H	Sharp active energy of the previous 12 settlement day	Float	kWh
00EAH	Sharp reactive energy for this month	Float	kvarh
00ECH	Sharp reactive energy of the previous 1 settlement day	Float	kvarh
00EEH	Sharp reactive energy of the previous 2 settlement day	Float	kvarh
00F0H	Sharp reactive energy of the previous 3 settlement day	Float	kvarh
00F2H	Sharp reactive energy of the previous 4 settlement day	Float	kvarh
00F4H	Sharp reactive energy of the previous 5 settlement day	Float	kvarh
00F6H	Sharp reactive energy of the previous 6 settlement day	Float	kvarh
00F8H	Sharp reactive energy of the previous 7 settlement day	Float	kvarh
00FAH	Sharp reactive energy of the previous 8 settlement day	Float	kvarh
00FCH	Sharp reactive energy of the previous 9 settlement day	Float	kvarh
00FEH	Sharp reactive energy of the previous 10 settlement day	Float	kvarh
0100H	Sharp reactive energy of the previous 11 settlement day	Float	kvarh
0102H	Sharp reactive energy of the previous 12 settlement day	Float	kvarh
0104H	Peak active energy for this month	Float	kWh
0106H	Peak active energy of the previous 1 settlement day	Float	kWh
0108H	Peak active energy of the previous 2 settlement day	Float	kWh
010AH	Peak active energy of the previous 3 settlement day	Float	kWh
010CH	Peak active energy of the previous 4 settlement day	Float	kWh
010EH	Peak active energy of the previous 5 settlement day	Float	kWh
0110H	Peak active energy of the previous 6 settlement day	Float	kWh
0112H	Peak active energy of the previous 7 settlement day	Float	kWh
0114H	Peak active energy of the previous 8 settlement day	Float	kWh
0116H	Peak active energy of the previous 9 settlement day	Float	kWh
0118H	Peak active energy of the previous 10 settlement day	Float	kWh
011AH	Peak active energy of the previous 11 settlement day	Float	kWh
011CH	Peak active energy of the previous 12 settlement day	Float	kWh
011EH	Peak reactive energy of this month	Float	kvarh
0120H	Peak reactive energy of the previous 1 settlement day	Float	kvarh
0122H	Peak reactive energy of the previous 2 settlement day	Float	kvarh
0124H	Peak reactive energy of the previous 3 settlement day	Float	kvarh
0126H	Peak reactive energy of the previous 4 settlement day	Float	kvarh
0128H	Peak reactive energy of the previous 5 settlement day	Float	kvarh
012AH	Peak reactive energy of the previous 6 settlement day	Float	kvarh
012CH	Peak reactive energy of the previous 7 settlement day	Float	kvarh
012EH	Peak reactive energy of the previous 8 settlement day	Float	kvarh

0130H	Peak reactive energy of the previous 9 settlement day	Float	kvarh
0132H	Peak reactive energy of the previous 10 settlement day	Float	kvarh
0134H	Peak reactive energy of the previous 11 settlement day	Float	kvarh
0136H	Peak reactive energy of the previous 12 settlement day	Float	kvarh
0138H	Flat active energy for this month	Float	kWh
013AH	Flat active energy of the previous 1 settlement day	Float	kWh
013CH	Flat active energy of the previous 2 settlement day	Float	kWh
013EH	Flat active energy of the previous 3 settlement day	Float	kWh
0140H	Flat active energy of the previous 4 settlement day	Float	kWh
0142H	Flat active energy of the previous 5 settlement day	Float	kWh
0144H	Flat active energy of the previous 6 settlement day	Float	kWh
0146H	Flat active energy of the previous 7 settlement day	Float	kWh
0148H	Flat active energy of the previous 8 settlement day	Float	kWh
014AH	Flat active energy of the previous 9 settlement day	Float	kWh
014CH	Flat active energy of the previous 10 settlement day	Float	kWh
014EH	Flat active energy of the previous 11 settlement day	Float	kWh
0150H	Flat active energy of the previous 12 settlement day	Float	kWh
0152H	Flat reactive energy for this month	Float	kvarh
0154H	Flat reactive energy of the previous 1 settlement day	Float	kvarh
0156H	Flat reactive energy of the previous 2 settlement day	Float	kvarh
0158H	Flat reactive energy of the previous 3 settlement day	Float	kvarh
015AH	Flat reactive energy of the previous 4 settlement day	Float	kvarh
015CH	Flat reactive energy of the previous 5 settlement day	Float	kvarh
015EH	Flat reactive energy of the previous 6 settlement day	Float	kvarh
0160H	Flat reactive energy of the previous 7 settlement day	Float	kvarh
0162H	Flat reactive energy of the previous 8 settlement day	Float	kvarh
0164H	Flat reactive energy of the previous 9 settlement day	Float	kvarh
0166H	Flat reactive energy of the previous 10 settlement day	Float	kvarh
0168H	Flat reactive energy of the previous 11 settlement day	Float	kvarh
016AH	Flat reactive energy of the previous 12 settlement day	Float	kvarh
016CH	Valley active energy for this month	Float	kWh
016EH	Valley active energy of the previous 1 settlement day	Float	kWh
0170H	Valley active energy of the previous 2 settlement day	Float	kWh
0172H	Valley active energy of the previous 3 settlement day	Float	kWh
0174H	Valley active energy of the previous 4 settlement day	Float	kWh
0176H	Valley active energy of the previous 5 settlement day	Float	kWh
0178H	Valley active energy of the previous 6 settlement day	Float	kWh
017AH	Valley active energy of the previous 7 settlement day	Float	kWh
017CH	Valley active energy of the previous 8 settlement day	Float	kWh
017EH	Valley active energy of the previous 9 settlement day	Float	kWh
0180H	Valley active energy of the previous 10 settlement day	Float	kWh
0182H	Valley active energy of the previous 11 settlement day	Float	kWh
0184H	Valley active energy of the previous 12 settlement day	Float	kWh
0186H	Valley reactive energy for this month	Float	kvarh
0188H	Valley reactive energy of the previous 1 settlement day	Float	kvarh
018AH	Valley reactive energy of the previous 2 settlement day	Float	kvarh
018CH	Valley reactive energy of the previous 3 settlement day	Float	kvarh
018EH	Valley reactive energy of the previous 4 settlement day	Float	kvarh
0190H	Valley reactive energy of the previous 5 settlement day	Float	kvarh
0192H	Valley reactive energy of the previous 6 settlement day	Float	kvarh
0194H	Valley reactive energy of the previous 7 settlement day	Float	kvarh
0196H	Valley reactive energy of the previous 8 settlement day	Float	kvarh
0198H	Valley reactive energy of the previous 9 settlement day	Float	kvarh
019AH	Valley reactive energy of the previous 10 settlement day	Float	kvarh
019CH	Valley reactive energy of the previous 11 settlement day	Float	kvarh
019EH	Valley reactive energy of the previous 12 settlement day	Float	kvarh

6.4 Wireless communication

KPM31 supports LoRa/4G/2.4G WiFi wireless communication. Lora adopts Modbus RTU transparent transmission method, and the channel (430-950MHz) and rate (7-12) need to be configured during use. WiFi and 4G use MQTT protocol. The specific configuration steps are as follows:

Step 1: Set the meter to debug mode

Enter the setting interface, find the "rCFG" option and set it to "yes" mode.



Then the meter will initialize the network configuration.

Note: If it is a WiFi wireless communication, you need to turn on the mobile hotspot and set the account to compere-debug and the password to kpm-debug. Then the device will connect to the default hotspot and connect to the Compere maintenance platform for configuration.

Note: The system only stays in yes status for a few seconds then it will go back to no. Once u changed to yes status and pressed 'ENTER' key, the reconfigure step is finished.

Step 2: 'KPM Config' APP meter setting

1. Download 'KPM Config' APP from Google play or Apple store. As Fig 1.

(The account to 'kpmconfig' and the password to 'kpmconfig' too.)

2. Click 'Smart Meter' to enter the code search page.

3. Search for devices: Input the production number to search. If the number is wrong, the search button will be grayed and cannot be clicked. If the number is correct, click the 'code search' button to identify the device.

4. Input the configuration parameters and submit:

4.1 Private server settings: This page is for the meters sending data to the customers' private server. Input private server address (support domain name and IP address), server port, MQTT account, MQTT pass-word, etc.

If using WiFi meter, the local WiFi name and Password are required.

4.2 communication setting: Input server address (support domain name & IP address), port, MQTT account, MQTT password and submit. The default information is for sending data to T@ENERGY cloud platform.

5. Wait for about 20 seconds for the meter to return status information. If the configuration is successful, it will display "Successfully issued, please continue", click 'exist' to return to the device ID search interface. Click 'next' for bulk quantity meters settings. It will enter the last setting page and retain the data set last time. Users only need to change the meter number and submit.

FAQ for network connection

1. Issuing timeout: data communication time out. It means these settings are not successfully or setting is succeeded but data return is failed.

Solution: Click 'OK' to stay on the device information page and wait for 30 seconds to see if the device is showing of fline. If yes (of fline), that means the setting is succeeded. If not (online), please submit again.

2. Parameter lost: Data lost during communication.

Solution: Click 'OK' to stay on the device information page and wait for 30 seconds to see if the device is showing of fline. If yes (offline), that means the setting is succeeded. If not (online), please submit again.

7 Common Failure Analysis

No display after device is powered on

- Check whether the power supply voltage and other wiring are correct, and the power supply voltage should be within the working range;
- Turn off the device and host computer, and then restart.

The device does not work properly after power-on

- Turn off the device and host computer, and then restart.

Incorrect voltage or current reading

- Check whether the wiring mode setting is consistent with the actual wiring method

The power or power factor is incorrect, but the voltage and current is correct

- Compare the voltage and current input of the actual wiring and the wiring diagram, and check whether the phase relationship is correct

RS-485 communication is abnormal

- Check whether the communication baud rate, ID and communication protocol settings of the host computer are consistent with the device; Please check whether the data bit, stop bit, check bit settings are consistent with the host computer

8 Product Quality Assurance

8.1 Quality Assurance

All new devices sold to users, within a certain number of years from the date of sale to users, are subject to free quality assurance for failures caused by defects in design, materials and workmanship. If the product is determined to meet the above warranty conditions, the supplier will repair and replace it free of charge.

The supplier may require the user to send the device back to the manufacturer to confirm whether the device is covered by the free warranty and repair the device.

8.2 Warranty Restrictions

The following devices are not covered by the free warranty:

- Damage caused by incorrect installation, use, and storage.
- Abnormal operation and application conditions beyond the product specifications.
- Devices repaired by organizations or persons not authorized by the company.
- Devices that have exceeded the free warranty period

9 Contact details

Henan Compere Smart Technology CO., LTD.

Telephone: +86-371-86181681

Fax: +86-371-67890037

Web: www.comperepower.com

Address: Unit 1, Building 38, Liandong U Valley, No. 352 Lianhua Street, High-tech Zone, Zhengzhou, China

The final interpretation of this manual is owned by Henan Compere Smart Technology Co., Ltd.

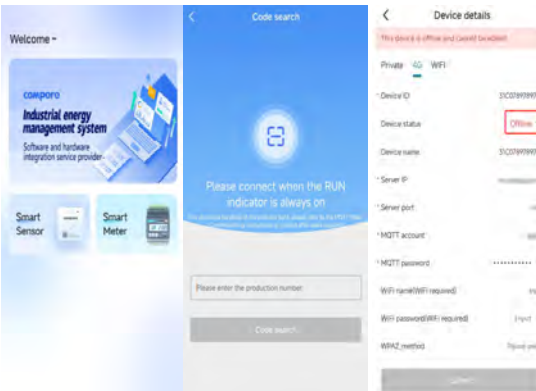

Fig1

Fig2

Fig3