

**Danger and Warning**

- The device can only be installed by professionals.
- The manufacturer will not take responsibility for failures caused by non-compliant operation not following this manual.

**Electric shock burning and explosion**

- Device should only be installed and maintained by qualified personnel.
- Before carrying out any operation on the device, isolate the voltage input and power supply, and short-circuit the secondary windings of all current transformers.
- Confirm that the voltage has been cut off before operation.
- All mechanical parts and covers, etc. should be restored to their original positions before the device is powered up.
- The device should be supplied with the correct rated voltage during use.

**1 Technical Parameters**

**1.1 Environmental conditions**

Operating temperature: -25°C~+70°C Storage temperature: -30°C~+75°C  
Relative humidity: 5%~95% No condensation Altitude :3000 meters below

**1.2 Rated parameters**

- Measuring range: Phase voltage L-N: 10~400VAC L-L: 90~660VAC
- Current: 0~800A(Depond on CTs)

Note: The pulse constant of the rated 5A is 3200imp/kwh.

The pulse constant of the external 100A CT is 1600imp/kwh.

The pulse constant of the external 400A and 800A CT is 900imp/kwh.

- Power consumption: AC voltage loop: <0.5VA / phase (rated)

AC current loop: <0.75VA / phase (5A)

<0.25VA / phase (1A)

- Device power supply circuit: <3VA

- Overload capacity:

AC voltage loop: 1.2 times rated voltage, continuous operation.

2 times rated voltage, allow 10S.

AC current loop: 1.2 times the rated current, continuous operation.

20 times rated voltage, Allow 1S.

- Precision index:

Parameter	Accuracy	Parameter	Accuracy
Voltage	±0.2%	Active energy	Build-in CTs: 0.5s
Current	Build-in CTs: ±0.2%	Reactive	External CTs: Class 1
	External CTs: ±0.5%		Class 2
Active power	Build-in CTs: 0.5s	Power factor	±0.5%
	External CTs: Class 1	Frequency	±0.02
	Class 2		

**2.4 Typical wiring**

KPM37 provides star system and triangular system wiring mode,the common wiring mode is as follows:

**2.4.1 Star system Y wiring**

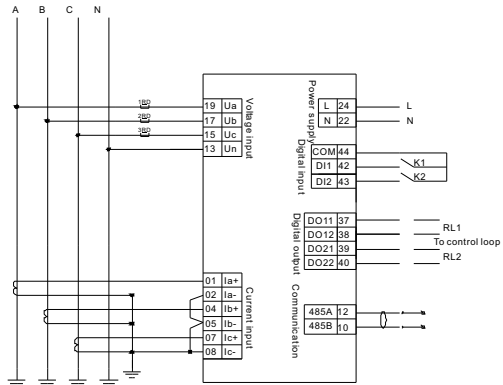

Four lines star system:Direct wiring without voltage transformer(PT) (The device is set to P4L)

**2.4.2 Triangle system Delta wiring**

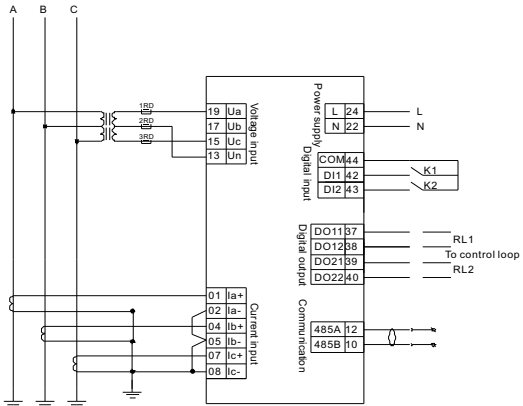

Triangle system: 2 voltage transformer(PT), 3 current transformers(CT) (device is set to P3L3)

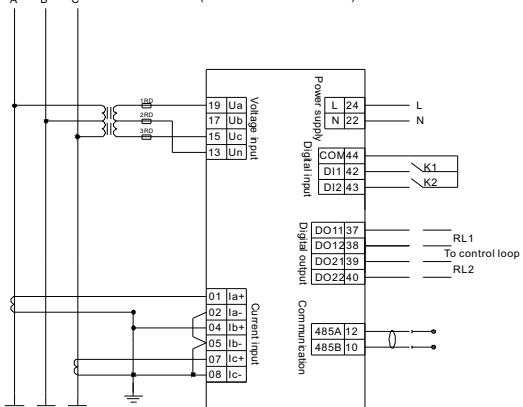

Triangle system: 2 voltage transformer(PT), 2 current transformers(CT) (device is set to P3L2)

**1.3 Electrical Insulation performance**

Power frequency withstand voltage:

Comply with GB /T13729, Power frequency voltage 2KV, Insulation resistance 1 minute.

Insulation resistance: Comply with GB / T13729, Insulation resistance ≥50MΩ

Impulse voltage: Comply with GB / T13729, withstand the impact of 1.2 / 50US, 5KV peak standard lightning.

**1.4. Mechanical properties**

Vibration response: IEC255-21-1, level 1

Vibration durability: IEC255-21-1, level 1

Impact response: IEC 255-21-2, level 1

Impact durability: IEC 255-21-2, level 1

Collision: IEC 255-21-2, level 1

**1.5. EMC performance**

Electrostatic discharge disturbance :IEC61000-4-2,level 4

Radiated electromagnetic field disturbance :IEC61000-4-3,level 4

Electric fast transient disturbance :IEC61000-4-4,level 4

Surge disturbance :IEC61000-4-5,level 4

Conducted immunity :IEC61000-4-6,level 3

Power frequency magnetic field disturbance :IEC61000-4-8,level 4

Pulse magnetic field immunity :IEC61000-4-9,level 4

Voltage dips and short interruptions test on A.C. power supply port :IEC61000-4-9,level 3

**2 Installation and wiring**

**2.1 Selection criteria**

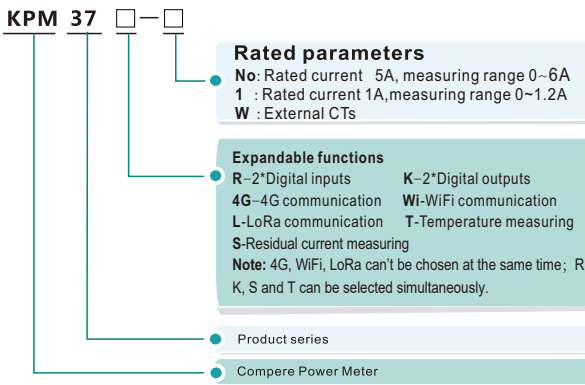

**KPM37 basic function:**

Three phase voltage, three phase currents, active power, reactive power, apparent power, active and reactive energy, power factor, frequency, 2-31st harmonic content, max&min value statistics, voltage and current imbalance rate, total power demand statistics, multi tariff power and historical power consumption statistics, load and operation time statistics, optional 4 wires temperature measurements and 2 wire digital inputs and outputs.1 wire Residual current.Multi rate electric energy statistics:5 kinds of rates, 2 sets of time zone tables, 2 sets of time interval tables. The MQTT protocol can transmit the 3rd, 5th and 7th harmonic content of voltage and current.

**3 Function Description**

**3.1 Power symbol**

KPM37 provides bidirectional power calculation, power and power factor polarity as shown in the figure.

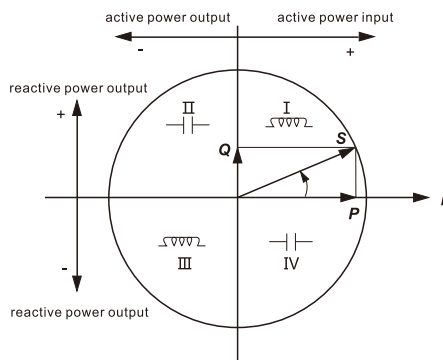

**3. 2. Power measurement**

KPM37 records positive and negative bidirectional active and reactive energy also records the sum of positive and negative bidirectional energy, records import and export energy net vaule.And multi rate electric energy statistics in the last 12 months. ABC split phase positive and negative active and reactive energy metering.

**3. 3. Wireless communication**

**Lora** : Working frequency band is: 430~525Mhz (default frequency 475.5Mhz). The theoretical transmission distance is 3.5km. This function needs to be paired with Compere Lora receiver module. Before use, please set two modules on the same channel and in transparent transmission mode. Lora communication adopts Modbus-RTU protocol, default baud rate is 9600 bps with no parity.

**4G** : Only works in client mode. MQTT and Modbus-RTU transparent protocol can be used to communicate with master. Need to set the master IP, port, MQTT account and password by 'KPM Config' APP.

**Wifi**: Only works in client mode. MQTT and Modbus-RTU transparent protocol can be used to communicate with master. Need to set the master IP, port, MQTT account, password WIFI name and password by 'KPM Config' APP.

**3.4. Switching Value input**

KPM37 provides 2-channel digital input, used to detect the circuit breaker position signal, switch position signal and other status information. DC24V power supply is provided inside the equipment, when the scene requires a switch input function, external access passive contact signal, when the external contact closed, the corresponding switch input state is also turned on.

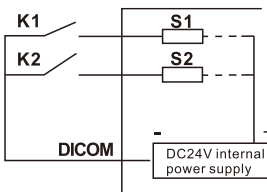

**3.5. Relay output**

KPM37 provides 2 relay action modes. The user should identify whether the relay is in remote mode or alarm mode. In different modes, the relays operate in different ways.

**2.2 Shape and opening size**

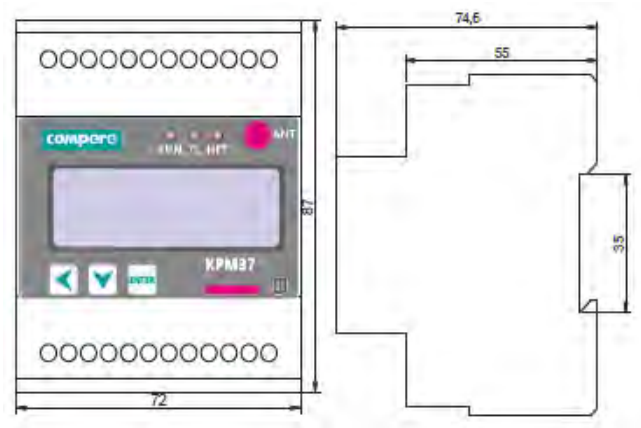

**2.3 Terminals**

**2.3.1 Current terminals**

01	02	03	04	05	06	07	08	09	10	11	12
Ia+	Ia-	Ib+	Ib-	Ic+	Ic-	B	A				

**2.3.2 Temperatures and pulse output terminals**

25	26	27	28	29	30	31	32	33	34	35	36
TN-	TN+	TC-	TC+	TB-	TB+	TA-	TA+	Q+	Q-	P+	P-

**2.3.3 Voltage, power supply, DO and residual current terminals**

13	14	15	16	17	18	19	20	21	22	23	24
Un	Uc	Ub	Ua	N	L						

37	38	39	40	41	42	43	44	45	46	47	48
DO11	DO12	DO21	DO22	DI1	DI2	COM	Ig+	Ig-			

Index	Mark	Define	Index	Mark	Define	Index	Mark	Define
1	Ia+	Phase A current +	17	Ub	Phase B voltage	33	Q+	Reactive pulse output+
2	Ia-	Phase A current -	18		Spare	34	Q-	Reactive pulse output-
3		Spare	19	Ua	Phase A voltage	35	P+	Active pulse output+
4	Ib+	Phase B current +	20		Spare	36	P-	Active pulse output-
5	Ib-	Phase B current -	21		Spare	37	DO11	Digital output 1
6		Spare	22	N	Power supply -	38	DO12	Digital output 1
7	Ic+	Phase C current +	23		Spare	39	DO21	Digital output 2
8	Ic-	Phase C current -	24	L	Power supply +	40	DO22	Digital output 2
9		Spare	25	Tn-	Temperature 4 input-	41		Spare
10	B	RS485B -	26	Tn+	Temperature 4 input+	42	DI1	Digital Input 1
11		Spare	27	Tc-	Temperature 3 input-	43	DI2	Digital Input 2
12	A	RS485A +	28	Tc+	Temperature 3 input+	44	COM	DI public terminal
13	Un	Voltage neutral line	29	Tb-	Temperature 2 input-	45		Spare
14		Spare	30	Tb+	Temperature 2 input+	46	Ig+	Residual current +
15	Uc	Phase C voltage	31	Ta-	Temperature 1 input-	47		Spare
16		Spare	32	Ta+	Temperature 1 input+	48	Ig-	Residual current -

**Remote mode:**

The relay is controlled by commands from the PC or PLC via communication.

**Alarm mode:**

The relay is controlled by an electrical parameter inside the device as a response to a set value control alarm condition.

**The 2 relays output modes:**

**Level mode:**

Relays maintain their open and closed states through levels, with high-level relays closed and low-level relays open. The relay remains disconnected after power off.

**Pulse mode:**

The action of the relay is achieved by outputting a pulse signal, with a default pulse duration of 200ms (which can be set).

Note: The control mode and output mode of the relay need to be set by the user according to the situation. The default control mode of the instrument is "remote mode", and the output mode is "pulse mode".

**3.6 Temperature measurement**

Optional 4-wire temperature measurement, accuracy is ± 1 ,using a 10kΩ 3950 NTC temperature sensor with an accuracy of 1%.Range:-20~100 .

**3.7 Residual current measurement**

Expandable 1 channel residual current measurement, measurement range: 0~1A, accuracy ± 1%. We need to use a 1000mA:0.5mA leakage current transformer with an accuracy requirement of 1%. It can be purchased by yourselves or equipped by our company (cost separately).

**4. Operating instructions**

**4.1.Interface display**



Index	Display content	Detailed Description
1	Menu indication	Includes Set, RT(running time), LT (Loading time)
2	Measurement data display	Display voltage, current, power, power factor, energy, frequency, parameter settings, etc.
3	Communication indication	The two small computers all disappeared, indicating no communication;Two small computers all show that the communication is normally received and sent.
4	Time indication	Display time or time statistics
5	Electrical energy type	Display: Imp (import power),Exp (Export power) Tot (Total power)
6	Unit symbol	Voltage: V, kV; Current: A, kA; Active power: W, kW; Reactive power var, kvar; apparent power:VA, kVA.
7	Multiple rate display symbol	Ⓢ: Sharp Ⓟ: Peak Ⓣ: Flat Ⓡ: Valley, Ⓢ & Ⓡ: Deep valley

**4.2 Operations**

There are 3 touch operation buttons on the panel. These 3 buttons are labeled as [Left] keys, [Down] keys, and [Enter] keys from left to right. The display of different measurement data and the setting of parameters can be realized by the operation of the three buttons.

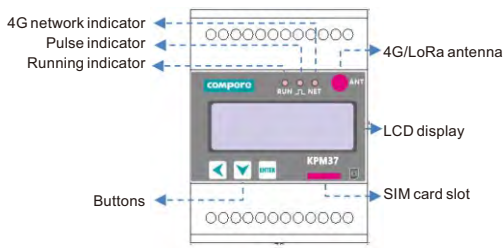

Name of key	Functional description
Left key	Switching power parameters display. If it is in the parameter setting state, it is used to move the bit to be modified
Down key	Switching power parameters display. If it is in the parameter setting state, it is used to increase the parameter values
Enter key	In the power parameter measuring state, it is used to enter the parameter setting interface. In the parameter setting state, it is used to enter the parameter setting state and confirm the parameter setting.
Left key+Enter key	Exit parameter setting state

In the electric parameter measuring state, press the **Left key** to switch to display the content as shown below. In the 3 phase 3 wire modes, the split phase voltage, split phase active power, reactive power, apparent power and power factor are not displayed in the interface.

Indicator description:

In Lora mode: the operation indicator flashes once for 1s regardless of whether the platform is connected or not; When the operation and maintenance platform or energy management platform is connected, the net indicator flashes according to the data transmission frequency.

In 4G/WiFi mode: when only connected to the operation and maintenance platform, the NET indicator will flash; When connected to the energy management platform, the NET indicator and the running indicator flash together.

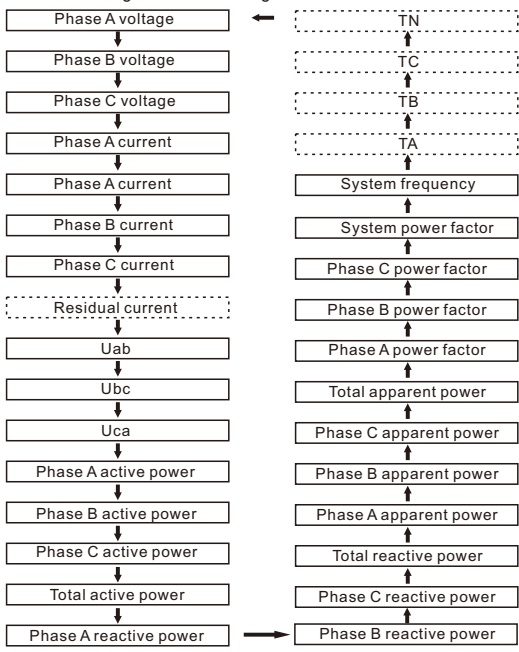

Note: The parameters in dotted box can only be displayed when the functions are selected.

In the power parameter measurement interface, press the **Down key** to enter the consumption and time query interface, press it continuously, the following interfaces will be displayed in turn.

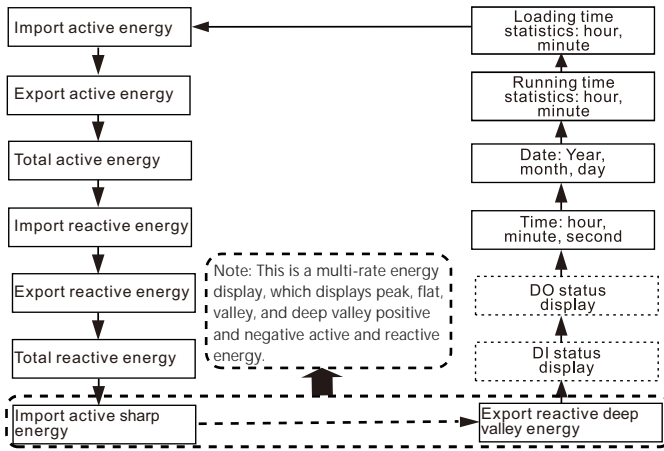

**Query interface for energy data, switch valve and time**  
Press the **Enter key** in the parameter measurement interface to enter the password input interface. The default password is 6666. After the password is entered, press the **Enter key** to confirm. If the input is correct, it will enter the parameter setting interface. If the input error, it will return to the measurement parameter display interface. In the parameter setting interface, Press **Down key** to switch the parameter item to be modified. Press **Enter key** button can enter the modification state of the parameter value, and it is accompanied by the flashing of the modified character. At this time, you can change the parameter size by pressing the **Down key**. After the modification, press the **Enter key** button to confirm, you can modify the next parameters. You can also press the **Left key** and the **Enter key** to exit the modification state and return to the measurement interface. When the user does not have any operation within 60 seconds in the parameter modification state, it will automatically return to the power parameter measurement display interface.

Parameter	Display character	Default value	Meaning
Password	PASS	6666	Used to protect it from non-staff personnel to modify instrument parameters
Wiring method	SYSS	P4L	P4L:3 phase 4 wire, P3L2 & P3L3 :3 phase 3 wire
Rated voltage	Un	220	Could be set to 100V, 220V
Rated current	In	5	Could be set to 1A 5A 100A 400A 800A
Voltage ratio	Pt	1.0	PT(0.1-6000.0)
Current ratio	Ct	1.0	CT(0.1-6000.0)
Communication address	Adr	1	Meter address for network communication 1-247
Baud rate	bPS	9600	Communication baud rate 1200~38400
Data format	dAtA	81n	Data frames format: 8 data bits, a parity bit and one stop bit
Backlight lighting time	blt	1	units : minute(0-120) ; If set to 0, the backlight will never go out
Demand time	dnnd	15	Unit: minute; the time window width in the calculation of the sliding window demand
System date	d.	Current date	Such as: 12.05.08
System time	t.	Current time	Such as: 09:35:20
Clear Electric energy	Eclr	Cleared	Used to clear the energy parameters.
Clear Max Min value	nclr	Cleared	Used to clear the maximum and minimum value
Password modification	PASS	6666	Default password 6666
Starting current	Ist	15	Meter starting current
Wiring direction	LinE	000	Can be set according to real current direction
Protocol selection	COMM	Mod	Default Modbus RTU, optional MQTT
Password setting	PASS	6666	Default password is 6666
Voltage loss threshold value	LV	20%	0-40% Un (Rated voltage)

Low voltage threshold value	uV	80%	0-100% Un (Rated voltage)
Over voltage threshold value	oV	120%	0-200% Un (Rated voltage)
Over current threshold value	oI	120%	0-200% In (Rated current)
Over load threshold value	oL	120%	0-200% Pn (Rated power)
Voltage imbalance threshold value	Unb	2%	0-100%
Current imbalance threshold value	Inb	10%	0-100%
Monthly demand date	S_d	1	1-28
Lora channel setting	CH	4755	4300-5250
Lora speed setting	Spd	07	07-12
Reboot Wireless	rSTC	no	Device reboot
communication setting	CoMt	LorA	0-Lora, 1-WiFi, 2-4G
Wireless protocol setting	UL_M	Mqtt	0-Mqtt, 1-toU (transparent)
Wireless reset	rCFG	no	Reset information in WiFi/4G mode
Log output	dbG	no	"YES" for log output by RS485
Second level data upload frequency	SECF	30	30, 60, 300, 900, 1200, 1800, 3600s
Minute level data upload frequency	MinF	05	01, 05, 10, 15, 20, 30, 60, 1440mins
Display SN	Sn_	Display 13 digit SN number, divided into two screens. When the SN is illegal, display "Err"	
Wireless Connection Status	MSTA: 0001: MQTT mode, disconnection; 0101: MQTT mode, connection is normal; 0002: Debug mode, disconnection; 0102: Debug mode, connection is normal Note: The first digit represents the signal strength, with 0-5 and 5 being the strongest		
Firmware version	AV4.5.2407		

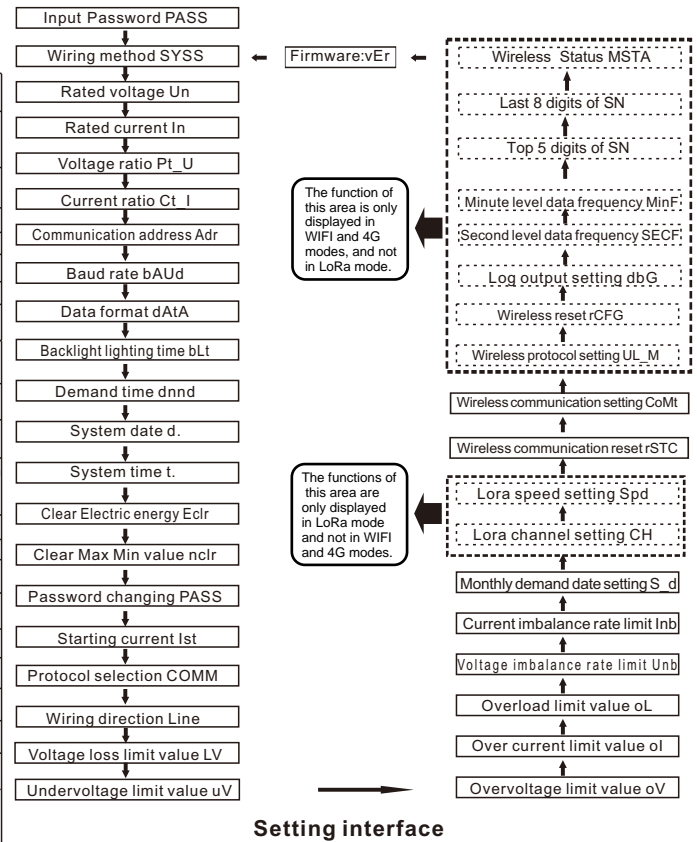

## 5. Communication

### 5.1 RS485 communication

KPM37 provides MODBUS-RTU communication protocol through RS485 port, with 1 start bit, 8-bit data bits, 1/0 odd even parity bit, 1 stop bits.

Each byte length is 11 bits.

Supported baud rates: 1200, 2400, 4800, 9600, 19200, 38400.

Factory default communication parameters: Modbus RTU protocol, 9600bps, no parity.

The format of the data frame is as follows:

Address field + Command field + Data field + CRC check area

Please contact supplier for Modbus-RTU protocol for more details.

Note: The minimum frame interval is 100ms.

### 5.2 Wireless communication

KPM37 has optional LoRa wireless point-to-point transparent transmission communication, WiFi wireless communication, and 4G wireless communication. Only one of the three can be used.

Through the device settings interface "CoMt" (wireless communication setting) to select.

#### 5.2.1 LoRa

Can be set on the meter, mainly to set the channel (4300~5250), communication speed (07~12). LoRa communication adopts Modbus-RTU protocol.

#### 5.2.2 WiFi/4G

KPM37 supports optional WiFi/4G wireless communication. The protocol can be selected between MODBUS RTU transparent or MQTT. The protocol can be set in wireless protocol setting (UL\_M). Both of them needs to be set in Touch Energy APP. Specific configuration steps are as follows:

##### Step 1: Set the meter to debug mode

Enter the setting interface, press **Left key** or **Down key** to enter the rCFG page and set it to "YES".

rCFG: YES

Press the **Enter key**, the position of "no" will flash, press **Left key**, it will be changed to "YES" status, and then press **Enter key**.

Note: The system only stays in YES status for a few seconds then it will go back to NO. Once u changed to YES status and pressed **Enter key**, the reconfigure step is finished.

At this time, the device will connect to the Compere maintenance platform. Then use the KPM Config APP to configure.

Note: If it is a WiFi wireless communication, you need to turn on the mobile hotspot and set the account to **compere-debug** and the password to **kpm-debug**. Then the device will connect to the default hotspot and connect to the Compere maintenance platform for configuration.

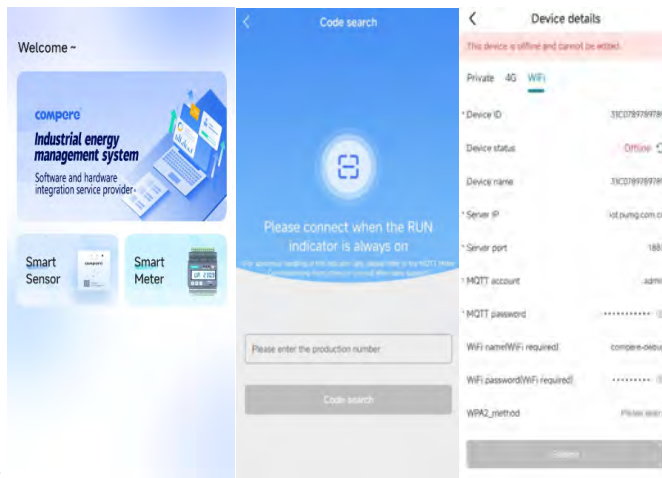

**Step 2: 'KPM Config' APP meter setting**  
1) Download 'KPM Config' from Google play or Apple APP store. (The account to 'kpmconfig' and the password to 'kpmconfig')  
2) Click 'Smart Meter' to enter the code search page. As Fig 1.  
3) Search for devices: Input the production number to search. As Fig 2. If the number is wrong, the search button will be grayed and can't be clicked. If the number is correct, click the "code search" button to identify the device.

4) Input the configuration parameters and submit:  
After entered the device details page, click refresh button in Device status until it's online.

##### • Private server settings

This page is for the meters sending data to the customers to private server. Input private server address (support domain name and IP address), server port, MQTT account, MQTT password, etc. If using WiFi meter, the local WiFi name and Password are required. WPA2 for enterprise level WiFi can be set too.

If using 4G meter, the WiFi name and Password is not required.

##### • 4G communication setting

Input server address (support domain name and IP address), port, MQTT account, MQTT password and submit. The default information is for sending data to T@ENERGY cloud platform.

##### • WiFi communication setting

Input server address (support domain name and IP address), port, MQTT account, MQTT password, local WiFi name and password (WPA2 for enterprise level WiFi can be set too) and submit. The default information is for sending data to T@ENERGY cloud platform.

5) Wait for about 20s for the meter to return status information.

If the configuration is successful, it will display "Successfully issued, please continue", click 'Exit' to return to the device ID search interface. Click "next" for bulk quantity meters settings. It will enter the last setting page and retain the data set last time. Users only need to change the meter number and submit.

Note: The device status will be of fine after submitted successfully.

## 6 Common Failure Analysis

### ➢ No display after device is powered on

- Check whether the power supply voltage and other wiring are correct, and the power supply voltage should be within the working range.
- Turn off the device and host computer, and then restart.
- The device does not work properly after power-on.
- Turn off the device and host computer, and then restart.

### ➢ Incorrect voltage or current reading

- Check the wiring mode setting.
- Check the PT and CT ratio.
- Check if GND is grounded properly.
- Check if the shield is grounded.
- Check if the PT and CT are in good condition.
- Power or PF is incorrect while the voltage and current is correct.

- Compare the voltage and current input of the actual wiring and the wiring diagram, and check whether the phase wiring is correct.
- RS485 communication is abnormal

- Check whether the communication baud rate, ID and communication protocol settings of the host computer are consistent with the device.
- Check whether the settings of data bits, stop bits and parity bits are consistent with those of the host computer.
- Check if the RS-232/RS-485 converter is normal.
- Check whether there is any problem with the entire communication network line (short circuit, open circuit, grounding, whether the shielded wire is properly grounded, etc.)
- Turn off the device and the host computer, and then turn it on again.
- It is recommended to connect a 100-200Ω in parallel at the end of the communication line.

### ➢ Wireless communication is abnormal

- Lora wireless communication  
Check whether the antenna placement, channel, speed and relative equipment are consistent.
- WiFi wireless communication  
Check whether the WiFi hotspot account and password are correct. Check if the WiFi can be connected to the Internet normally
- 4G wireless communication  
Check 4G antenna placement, server is normal, if SIM card is in arrears

## 7. Contact information

Henan Compere Smart Technology CO., Ltd.  
Telephone: +86-371-67890039 Fax: +86-371-67890037  
Sales hotline: +86-86181681 Web: www.comperepower.com Address Unit 1, Building 38, Liandong U Valley, No. 352 Lianhua Street, High-tech Zone, Zhengzhou, China

The final interpretation of this manual is owned by Henan Compere Smart Technology CO., Ltd.