

Danger and Warning

The device may only be installed by professionals. Caused any malfunction due to not follow the instructions in this manual, Manufacturers will not bear any responsibility.

Electric shock burning and explosion

- Devices can only be installed and maintained by qualified staff.
 - Before any operation on the Devices, should be isolated from the voltage input and power supply, and the secondary windings of all current transformers are Short circuit.
 - Verify that the device is live before operation.
 - All mechanical parts and covers should be restored in place before the device is energized.
 - Device in use should provide the correct voltage.
- Do not pay attention to these precautions may cause serious injury.*

1. Technical Parameters

1.1 Environmental conditions

Operating temperature: -25°C ~ +70°C Storage temperature: -30°C ~ +75°C

Relative humidity: 5% ~ 95% No condensation

Altitude :3000 meters below

1.2 Rated parameters

Device working power supply :85~265VAC , 80~300VDC

Rated AC data : Voltage:3* 57.7/100VAC , 3* 220/380VAC

AC current : Standard 5A (1A optional, please note before order)

Frequency : 50Hz

Switching input: Internal 24VDC power supply Debounce time 40ms

Switching output: Small high-power relays

Contact capacity 250VAC/5A,30VDC/5A

Power consumption: AC voltage loop < 0.5VA / phase (rated)

AC current loop < 0.75VA / phase (5A)

< 0.25VA / phase (1A)

Device power supply circuit: <3VA

Overload capacity:

AC voltage loop 1.2 times rated voltage, Continuous operation.
2 times the rated voltage , allow 10S.

AC current loop: 1.2 times the rated current,Continuous operation.

20 times the rated voltage , Allow 1S.

Precision index

Parameter	Accuracy	Resolution	Parameter	Accuracy	Resolution
Voltage	±0.2%	0.01V	Power factor	±0.5%	0.001
Current	±0.2%	0.01A	Active energy	±0.5%	0.1kWh
Active power	±0.5%	0.1W	Reactive	±2%	0.1kvarh
Reactive power	±2%	0.1var	frequency	±0.02	0.01Hz
Apparent power	±0.5%	0.1VA	temperature	±1°C	1°C

1.3 Electrical insulation performance

Power frequency withstand voltage: In line with GB /T13729-2002 provisions, Power frequency voltage 2KV,Insulation resistance 1 minute.

Insulation resistance: In line with GB / T13729-2002 provisions, Insulation resistance ≥50MΩ

Impulse voltage: In line with GB / T13729-2002 provisions, can bear the impact of 1.2 / 50US, 5KV peak standard lightning.

1.4 Mechanical properties

Vibration response: GB / T11287-2000 provisions, Harsh grade level 1

Vibration durability: GB/T11287-2000 provisions, Harsh grade level 1

Impact response: GB/T14537-1993 provisions, Harsh grade level 1

Impact durability: GB/T14537-1993 provisions, Harsh grade level 1

Collision: GB/T14537-1993 provisions, Harsh grade level 1

1.5 EMC performance

Electrostatic discharge immunity: GB / T17626.2-2006 level 4

Fast pulse group immunity: GB / T17626.4-2008 level 4

Surge immunity: GB / T17626.5-2008 level 4

Power frequency magnetic field immunity: GB / T17626.8-2008 level 4

2. Installation and wiring

2.1 Shape and hole size

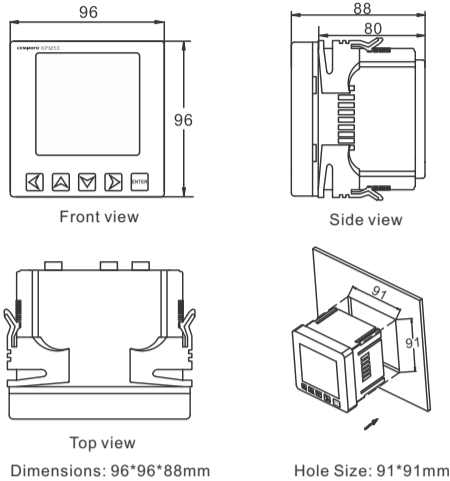

2.2 Terminal

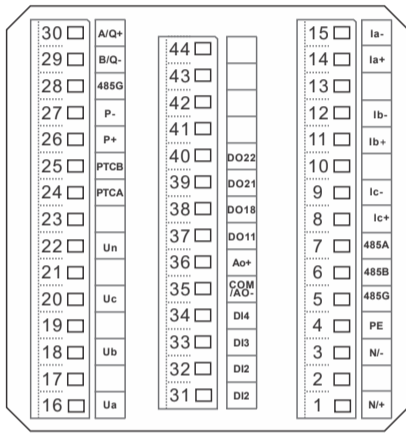

2.3.2 Triangular system

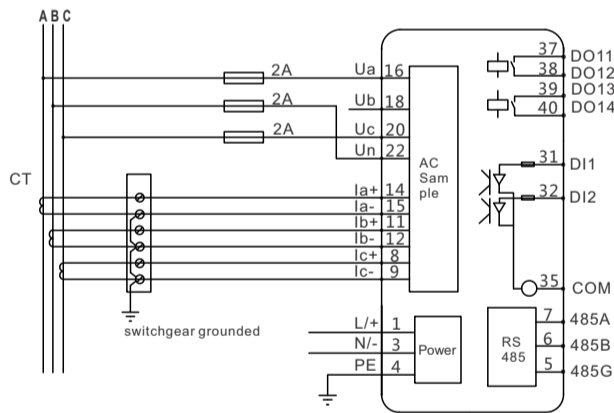

Triangle system: No voltage transformer(PT), 3 current transformers(CT) (device is set to 2LL3Ct)

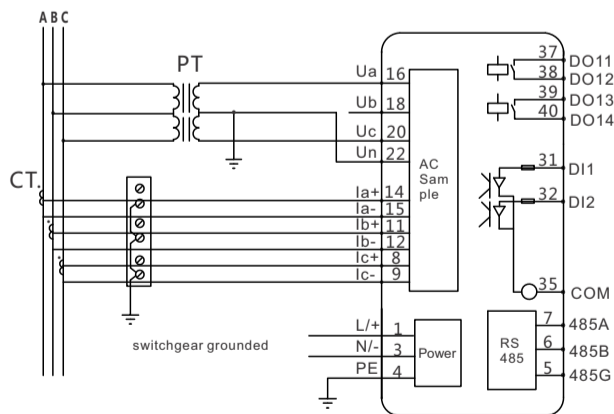

Triangle system: 2 voltage transformers (PT), 3 current transformers (CT) (device set to 2LL3Ct)

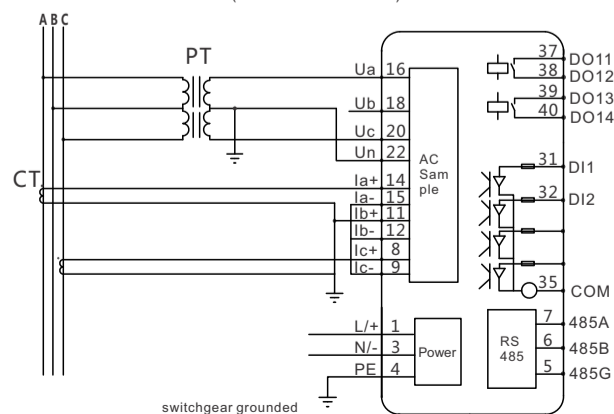

Triangle system: with two voltage transformers (PT), two current transformers (CT) (device set to 2LL2Ct)

3. Function Description

3.1 Power symbol

KPM53 provides bidirectional power calculation, power and power factor polarity as shown in the figure

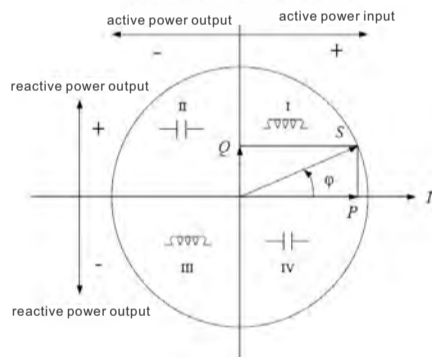

3.2 Power measurement

KPM53 bidirectional recording power sum of active and reactive energy, and the negative bi-directional power, voltage and current negative net power, can be extended to record this month, last month, and the month before last month of active and reactive energy value.

3.3 Switching Value input

KPM53 provide 2-channel switch input, used to detect the circuit breaker position signal, switch position signal and other status information. DC24V power supply is provided inside the equipment, when the scene requires a switch input function, external access passive contact signal, when the external contact closed, the corresponding switch input state is also turned on.

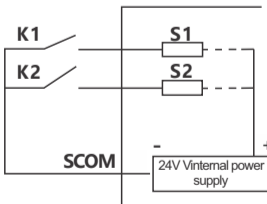

3.4 Delay output

KPM53 provides two kinds of relay action modes. The user should identify whether the relay is in remote control or over limit alarm control. In different control modes, the relays operate in different ways.

Remote control:

The relay is controlled by commands from the PC or PLC via communication.

Over limit alarm control:

The relay is controlled by an electrical parameter inside the device as a response to a set point control alarm condition.

The two relays operate as follows:

Remote control:

The relay closes by accepting a PC or PLC command. The relay status will remain until the PC or PLC issues a release command or the meter loses power.

Over limit alarm control:

When the trigger relay's alarm signal is generated, the relay operates. The relay is not released until all the alarm conditions for the trigger relay have disappeared or the meter has lost power. If the meter resumes power and the alarm condition still exists, the relay will act again.

Index	Mark	Define	Index	Mark	Define
1	L/+	Positive	21		
2			22	Un	Voltage neutral line
3	N/-	Negative	23		
4	PE	Ground	24	PTCA	Temperature Input Forward
5	485G	Communication shielded ground	25	PTCB	Temperature input negative
6	485B	RS485 negative	26	P+	Pulse output positive
7	485A	RS485 positive	27	P-	Pulse output negative
8	Ic+	C-phase current into the line	28	485G	Communication shielded ground
9	Ic-	C-phase current outlet	29	B/Q-	RS485 Negative or reactive pulse output negative
10			30	A/Q+	RS485 Positive or reactive pulse output positive
11	Ib+	B-phase current into the line	31	DI1	Switch input 1
12	Ib-	B-phase current outlet	32	DI2	Switch input 2
13			33		
14	Ia+	A-phase current into the line	34		
15	Ia-	A-phase current outlet	35	COM AO-	A common terminal of switch Negative analog output
16	Ua	Phase A voltage	36	AO+	Positive analog output
17			37	DO11	Relay output 1 forward
18	Ub	Phase B voltage	38	DO12	Relay output 1 negative
19			39	DO21	Relay output 2 forward
20	Uc	Phase C voltage	40	DO22	Relay output 2 negative

Note: 5,6,7 terminal configured as a standard RS485, Terminals 29 and 30 are reactive pulse outputs. It can be expanded 1 RS485 interface, and can expand Profibus-DP communication.

2.3 Typical wiring

KPM53 provides star system and triangular system wiring mode, the common wiring mode is as follows:

2.3.1 Star system wiring (<400V/690V system)

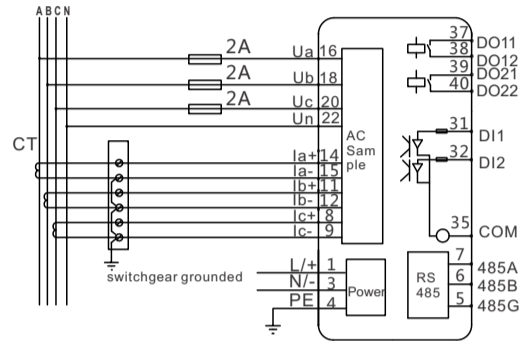

Four lines star system: Direct wiring without voltage transformer(PT) (The device is set to 3Ln3Ct)

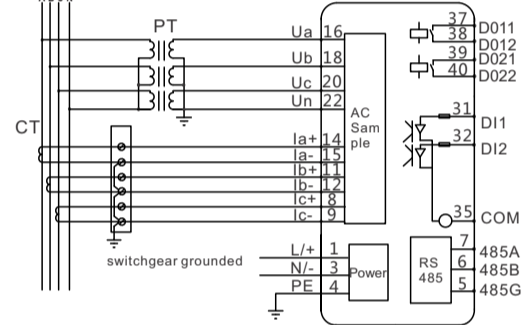

Four lines star system: 3 voltage transformers(PT) 3 current transformers(CT) (device is set to 3Ln3Ct)

3.5 Pulse

KPM53 provides active / reactive energy metering, 1 active energy pulse output, and adopts the optocoupler electrode open circuit output. The method of energy accuracy inspection refers to the national measurement protocol: Pulse error comparison method of standard table.

Electrical characteristics: Open collector voltage VCCs48V, current Iz ≤50mA; Pulse constant: 3200imp/kWh. It means when the meter accumulated 1kWh, the pulse output number is 3200. It is emphasized that 1kWh is the secondary side of the electric energy data. In the case of PT and CT, the relative N pulse data corresponds to the primary side energy is N ÷ 3200 × voltage transformation ratio × current transformation ratio (kWh) Application examples:

The external pulse counting device, assumes that the number of pulses collected during a period of length T is N, and the instrument input is: 10kV/100V, 400A/5A, then the instrument energy accumulation during this time period is N ÷ 3200 × 100 × 80 kWh.

3.6 Analog output

Analog output 4mA corresponds to the lower limit of the range, 20mA corresponds to the upper range. When the range is exceeded, the transmission current increases linearly. The maximum effective output is 120% of the range, the maximum output current is 24mA, and the maximum load resistance is 400 ohms. The transmission curve is as follows

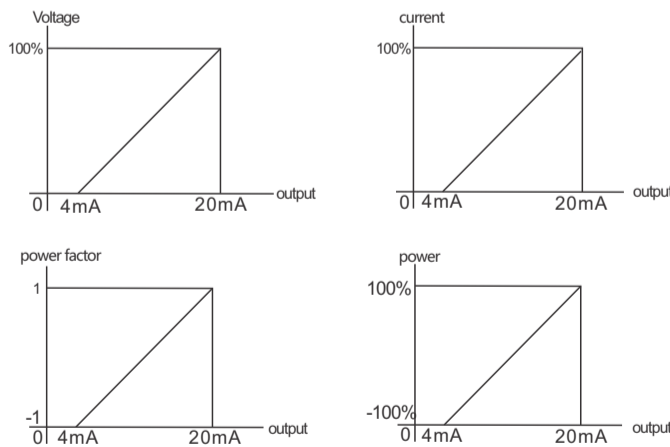

Explanation: P=(Px-12) × Pe × CT × PT/8, Px is the actual analog measured value, the unit is mA; Pe is the corresponding rated power, unit W. PE value varies under different voltage levels, as follows:

220V/5A: Pe=3300W 220V/1A: Pe=660W
100V/5A: Pe=1500W 100V/1A: Pe=600W

Note: When transmitting single-phase power, Pe = rated voltage × rated current.



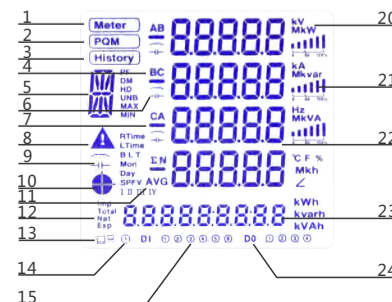

4. Operating instructions

4.1 Interface display







index	Display content	Detailed Description
1	Real-time data	contain basic electrical parameters, total power data, time, etc.
2	Power Quality	contain demand, harmonics, voltage and current imbalance and so
3	Historical data	contains maximum and minimum value, etc
4	Phase sequence indication	Indicated A, B, C-phase value, AB, BC, CA three-line value and total reactive power, total apparent power and so on, N represents zero line
5	Measurement data type	Identifies the parameter name displayed in the current measurement data display area in alphabetical form : Voltage 'U' Current is 'I' Active power 'P' Reactive power 'Q' Apparent power 'S' Power factor 'PF' Frequency 'F' Demand 'DM' Harmonic 'HD' Unbalance 'UNB' Maximum 'Max' Minimum 'Min', Temperature 'T' Meter operation time 'RTime' Load time 'LTime' Two months ago 'B Mon' Last month 'L Mon' This month 'T Mon' Yesterday 'LDay' Today is 'T Day' The day before yesterday 'B Day'
6	Each phase of the load nature indication	Inductance symbol light: Indicates that it is an inductive load at this time, now, Q>0; Capacitance symbol light: Indicates that it is a capacitance load at this time, now, Q<0;
7	Negative sign	Display when the measured data is negative
8	Alarm	Display when there is alarm signal
9	Total load property indication	Inductance symbol light: Indicates inductive load at this time, $\Sigma Q > 0$; Capacitance symbol light: Indicates capacitive load at this time, $\Sigma Q < 0$;
10	Load quadrant indication	The quadrant of the system power is displayed in quadrant diagrams. The first quadrant $\Sigma P > 0$ and $\Sigma Q > 0$, the second quadrant $\Sigma P < 0$ and $\Sigma Q > 0$, the third quadrant $\Sigma P < 0$ and $\Sigma Q < 0$, the fourth quadrant $\Sigma P > 0$ and $\Sigma Q < 0$.
11	average value	Data show average
12	Electrical type indication	Imp : Forward electrical metric ; Exp : reverse electric metric ; Total : Absolute value , the sum of the absolute values of the forward electrical and reverse electrical metric ; Net : net electrical degrees , The absolute value of the difference between Forward electrical metric and reverse electric metric.
13	Communication indication	If two small computers sign are all faded, it means there is no communication message; two small computers sign all show means the communication transceiver is proper functioning.
14	Clock indication	When this sign light, it indicates area 17 displays time data.
15	Switch input status	When there is a digital display, it indicates that the corresponding loop switch is closed.
16	Relay output status	When there is a digital display, it indicates that the corresponding loop relay is closed.
17	Power and time area	Display a variety of electrical measurement data, real-time clock, parameter settings, etc.
18	Measurement data display area	Display the main measurement data: voltage, current, power, power factor, frequency, temperature, harmonic data, demand, maximum, minimum, parameter setting data, etc.
19	Each phase load histogram	Load : Load size display ; Directly indicate the percentage of the load current relative to the rated current in the form of a histogram.
20	Electrical parameter unit symbol	voltage : V , kV. Current : A , kA. Activepower : W , kW , MW. Reactive power: var, kvar, Mvar. Apparent power : VA , kVA , MVA. Frequency : Hz. Active electricity : kWh. Reactive electricity: kvarh ;

4.2 Operation display

There are five touch buttons on the front panel, the five keys are marked as key left , key up , key down , right key , key enter . Through the operation of five keys can be achieved in different measurement data display and parameter settings.



Button name	Functional description
 Left key	Switch the three major functions display interface: "Meter", "PQM", "History"; in the parameter setting state as "return" key.
 Up key  down key	In different function display interface, press the up or down key to cycle through all the parameters of present function. In the parameter setting mode , press up to increase the value of the modified bit in the parameter setting state. Press down to decrease the value of the modified bit.
 Right key	During "Meter" display, press this key to cycle the energy data; In the "PQM" power quality display, pressing this button cycles display demand, the harmonics, voltage and current imbalance. Under "History" display, press this button to show the maximum minimum value. In parameter setting state, it is used to move the bits to be modified.
 ENTER	Confirm to enter the programming state; in the parameter setting state, it is used to enter the menu, programming parameters and confirmation.

Measurement display menu structure as follows:

Press left button, the screen shows cyclically as following FIGS,

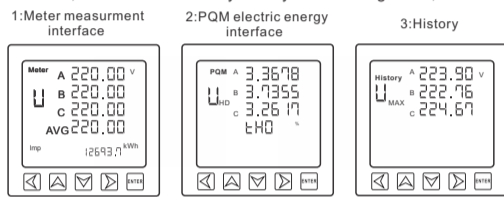

In "Meter" interface, press  key or  key to display real-time measurement data in turn, as shown,

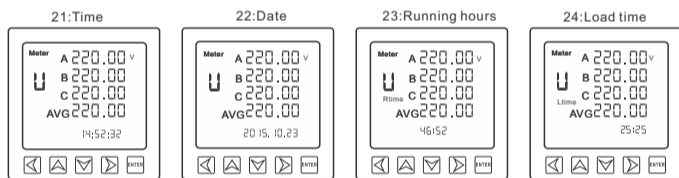
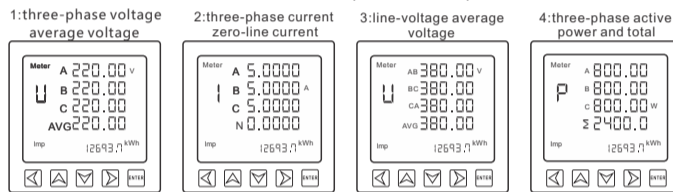

In the "PQM" interface, press right key, the screen will display electric energy quality cyclically , as shown below:

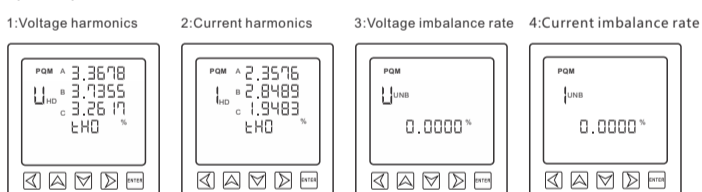

When "HD" is on, you can use the down key or up key to see the three-phase voltage and current harmonic total distortion rate and 2 - 31 harmonic content. The upper left corner shows "U", for this parameter indicates a three-phase harmonic voltage, when display "I", for this parameter indicates a three-phase harmonic current, the first three lines show the total harmonic distortion and fractional harmonic content, the fourth line represents the current harmonic data type, the total harmonic distortion is displayed when "THD" is displayed, when "HR" is displayed, the data indicates the fractional harmonic content, 2 - 31 corresponds number of harmonics.

In the "History" display interface, right-click to display the max or min value, press the down key to turn down or turn up with the up key to display the interface shown below. At the same time, the screen shows "MAX" characters on the left when the data is the maximum value, the data is the smallest left when the display "MIN" characters.

4.3 parameter setting

Press the ENTER key to enter the password input interface, the default password is 6666. Press the ENTER key for confirmation after the password input. If input action is correct, the system will enter the parameter setting interface. If the input is wrong, it will return to the display interface of the measurement parameters.

Press UP key or DOWN key to switch the modifying parameters. Press the ENTER key to enter the parameter value modify state, and accompanied with flashing for modification of the characters. After the setting is completed, press the ENTER key to confirm the parameters changing. Then you can modify the next parameter, or you can also press LEFT button to exit the parameters modifying state, return to the measurement interface. When the user has no operation in 60 seconds in the parameters modifying state, the system will automatically return to the electrical parameter measurement display interface.

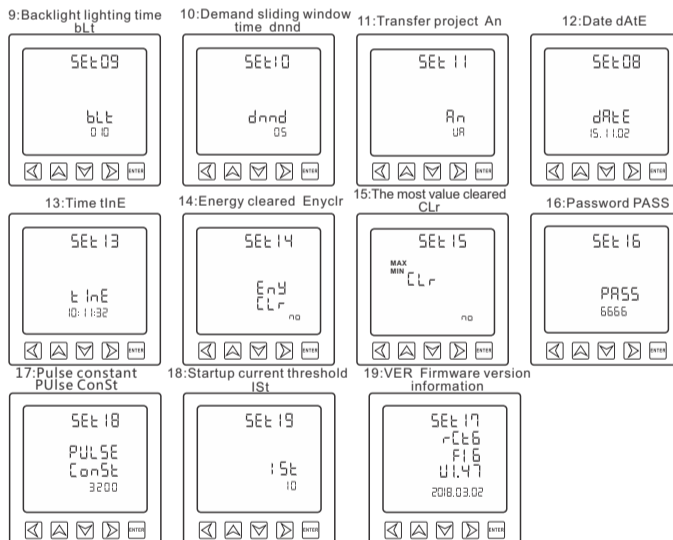
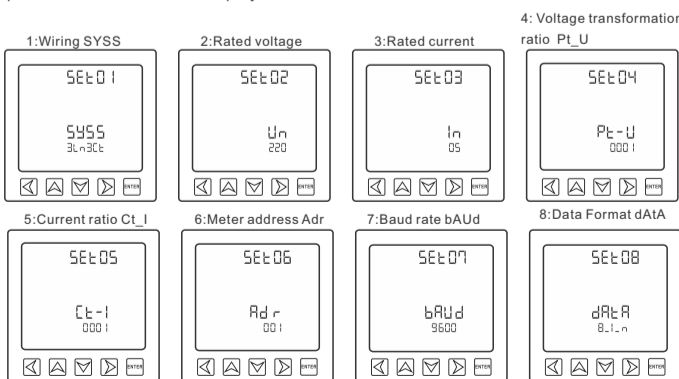

Note: It will display different No. according to different setting function .

Factory default value

parameter	Display	Default	implication
Password protection	PASS	6666	Used to protect non-staff to modify
Wiring method	SYSS	3Ln3CT	Three-phase four-wire system , 2LL2CT and 2LL3CT are Three-phase three-wire system
Rated voltage	Un	220	Could be set as 100, 220, 400
Rated current	In	5	Could be set as 1, 5, 10
Voltage ratio	Pt_U	1	Voltage transformer ratio : 1~9999
Current ratio	Ct_I	1	Current transformer ratio : 1~9999
Communication address	Adr	1	The address of the meter when the network is in communication, 1~247
Baud rate	baud	9600	Communication Baud rate address 1200~38400
Data format	dAtA	81N	Data frame format : 8 data bits, a parity bit and one stop bit
Backlight lighting time	blt	1	units : minute ; If set to 0, the backlight will never go out; set to other values, the light will go off after the setting time delay after the last key press.
Transmitting	An	Ua	3Ln3CT can be sent to the project: Ua, Ub, Uc, Ia, Ib, Ic, Uab, Ubc, Uca, Pa, Pb, Pc, P, Qa, Qb, Qc, Q, Sa, Sb, Sc, S, Pfa, Pfb, Pfc, Pff; 2LL2CT and 2LL3CT can be sent to the project: Ia, Ib, Ic, Uab, Ubc, Uca, P, Q, S, P, F, F;
System data	dAtE	Current date	Such as : 2012.05.08
System time	tinE	Current time	Such as : 09:35:20
Clear Electric energy	cLr Eny	Cleared	Used to clear the energy parameters.
Clear Max Min value	cLr MaxMin		Used to clear the maximum and minimum value
Pulse constant	Pulse Const	3200	The firmware program version and date of the device
Startup current	IST	10	Setting range 400~9999
Firmware version	Ver		Setting range 1~9999mA

5. Communication

KPM53 multifunction meter provides MODBUS-RTU communication protocol, a start, 8-bit data bits, 1/0 parity, 1/2 stop bits. Each byte length is 11 bits.

Supported baud rates: 1200, 2400, 4800, 9600, 19200, 38400.

Factory default communication parameters: 9600, no parity, 1 stop bit.

RTU mode format for each byte:

1 start bit + 8 data bits + 1 parity bit + 1 stop bit

The format of the data frame is as follows:

Address field + Command field + Data field + CRC check area

Note: The minimum frame communication interval is 100ms.

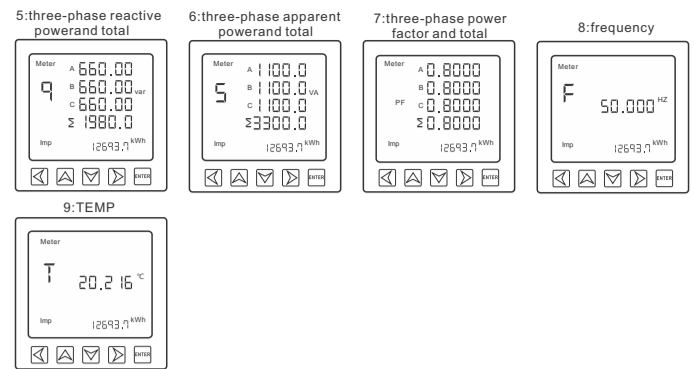

In the "Meter" interface, right-click to enter the electric energy and time query interface, press the right button continuously to display the interface as the following FIG shown. When the time and date are displayed, the clock pattern is displayed in the lower left corner of the screen. When the energy accumulated more than 99999999.9, the hexadecimal representation of the floating point number of the energy accumulated value is displayed, F indicates that the maximum display value is exceeded.

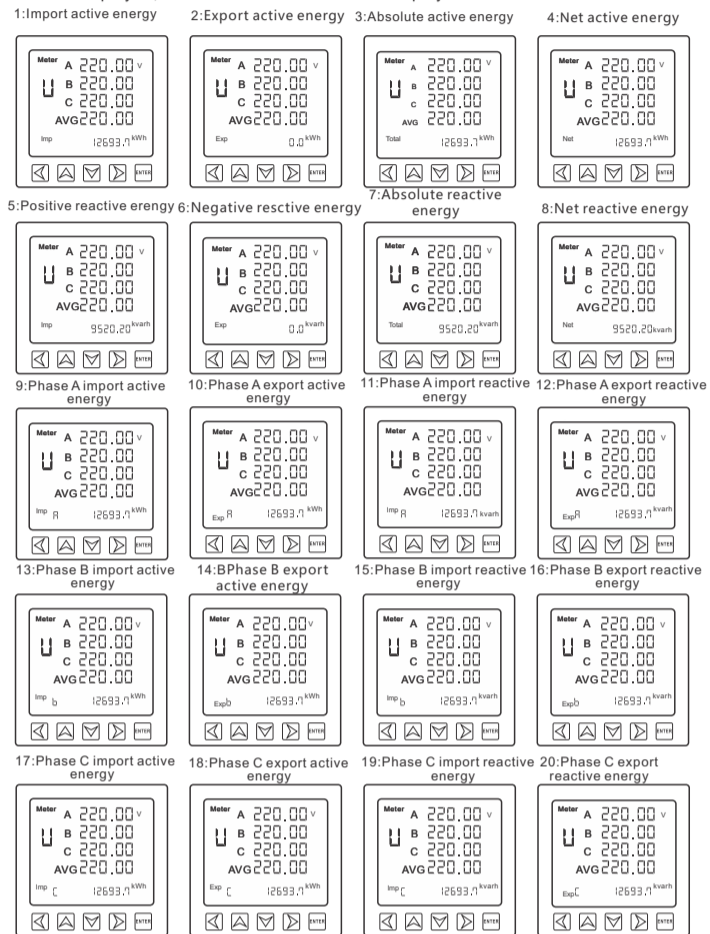

Supported function codes			
DEC	HEX	definition	Operation description
01	0x01	Read relay output	Read one or more relay outputs
02	0x02	Read switch input	Read one or more switch input
03	0x03	Read register data	Read the value of one or more registers
05	0x05	Write a single relay output	Control all the way to close or disconnect the relay
06	0x10	Write multiple registers	Write multiple register data at a time

6. Common malfunction Analysis

- Nothing is displayed after the unit is powered on
 - Check if the supply voltage and other wiring are correct, also the supply voltage should be within the operating range
 - Turn off the device and the host computer, and then reboot
- The device is not working properly after power on
 - Turn off the device and the host computer, and then reboot
- Voltage or current readings incorrect
 - Check if the wiring mode setting matches the actual wiring mode
 - Check whether the voltage transformer (PT) and current transformer (CT) ratio are set correctly
 - Check if GND is grounded properly
 - Check if the shield is grounded
 - Check if the voltage transformer (PT) and current transformer (CT) are intact
- The power or power factor reading is incorrect, but the voltage and current readings are correct
 - Compare the voltage and current input of the actual wiring and wiring diagram, and check if the phase relationship is correct.
- RS-485 communication is not working properly
 - Check whether the communication baud rate, ID and communication protocol settings of the host computer are consistent with the meter
 - Please check the data bits, stop bits, parity settings and the host computer is consistent
 - Check if the RS-232 / RS-485 converter is working properly
 - Check if there are the problems in the entire communications network lines (Such as short circuit, open circuit, grounding, if the shield is properly grounded at one end, etc.)
 - Turn off the device and the host computer, and then reboot
 - If the communication line is longer, it is recommended to parallel connect a 100~200 Ω matching resistors at the end of the communication line.

Note: If there are any unsolved problems, please contact our company's after-sales service department.

7 Contact Details

Henan Compere Smart Technology CO., LTD.

Telephone: +86-371-86181681

Fax: +86-371-67890037

Web: www.compere-power.com

Address: Unit 1, Building 38, Liandong U Valley, No. 352 Lianhua Street, High-tech Zone, Zhengzhou, China

The final interpretation of this manual is owned by Henan Compere Smart Technology Co., Ltd.