

**Danger and Warning**

The device may only be installed by professionals. Caused any malfunction due to not follow the instructions in this manual, Manufacturers will not bear any responsibility.

**Electric shock burning and explosion**

- Devices can only be installed and maintained by qualified staff.
  - Before any operation, the device should be isolated from the voltage input and power supply, and short circuit the secondary winding of all current transformers.
  - Verify that the device is live before operation.
  - All mechanical parts and covers should be restored in place before the device is energized.
  - Device in use should provide the correct voltage.
- Not paying attention to these precautions may cause serious injury.*

**1. Technical Parameters**

**1.1 Environmental conditions**

Working temperature: -25°C ~ +70°C  
Storage temperature: -30°C ~ +75°C  
Relative Humidity: 5% ~ 95%  
Non-condensing Altitude: 3000 meters or less

**1.2 Rated parameters**

Device operating power: AC 85~265V, DC 100~310V  
Rated AC data: Phase voltage 57.7V/220V/400V  
AC current 5A or 1A (ordering instructions)  
Frequency 50Hz

Digital input: Internal supply of DC 24V power  
Debounce time 40ms

Relay output: Small high-power relay  
Contact capacity 250VAC/5A, 30VDC/5A

Power consumption: AC voltage loop less than 0.5VA/phase (rated)  
AC current loop less than 0.75VA/phase (at 5A)  
Less than 0.25VA/Phase (at 1A)

Unit Power Circuit Less than 3VA

Overload capability: AC voltage loop 1.2 times rated voltage, continuous operation  
2 times rated voltage, 10s allowed  
AC current loop: 1.2 times rated current, continuous operation  
20 times rated current, allow 1s

**Precision index**

Parameter	Accuracy	Resolution	Parameter	Accuracy	Resolution
Voltage	±0.2%	0.01V	Power factor	±1%	0.001
Current	±0.2%	0.01A	Active power	±0.5%	0.1kWh
Active energy	±0.5%	0.1W	Reactive power	±2.0%	0.1kvarh
Reactive	±2.0%	0.1var	Frequency	±0.02	0.01Hz
Apparent power	±0.5%	0.1VA	Temperature	±1°C	0.1°C

**1.3 Electrical insulation performance**

Power frequency withstand voltage: Conforms to the provisions of GB/T13729-2002  
power frequency voltage 2KV, time 1 minute  
Insulation resistance: Conforms to the provisions of GB/T13729-2002, the insulation resistance is not less than 50MΩ  
Impulse voltage: Conforms to the provisions of GB/T13729-2002, bear the shock of 1.2k/50US peak for 5kV standard lightning

**1.4 Mechanical properties**

Vibration response: GB / T11287-2000 provisions, Harsh grade level 1  
Vibration durability: GB/T11287-2000 provisions, Harsh grade level 1  
Impact response: GB/T14537-1993 provisions, Harsh grade level 1  
Impact durability: GB/T14537-1993 provisions, Harsh grade level 1  
Collision: GB/T14537-1993 provisions, Harsh grade level 1

**1.5 Electromagnetic compatibility**

Electrostatic discharge immunity: GB / T17626.2-2006 level 4  
Fast pulse group immunity: GB / T17626.4-2008 level  
Surge immunity: GB / T17626.5-2008 level 4  
Power frequency magnetic field immunity: GB / T17626.8-2008 level 4

**2. Selection, Installation and Wiring**

**2.1. Shape and opening size**

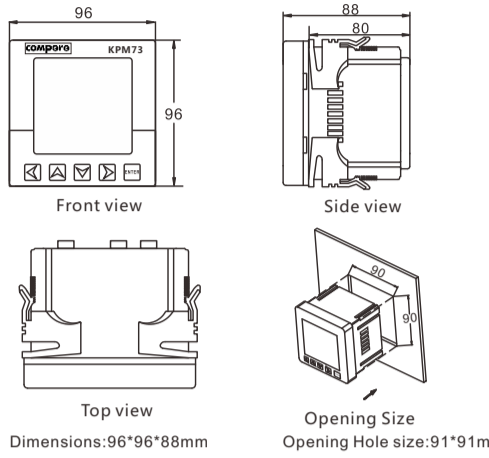

**2.2 Terminal wiring**

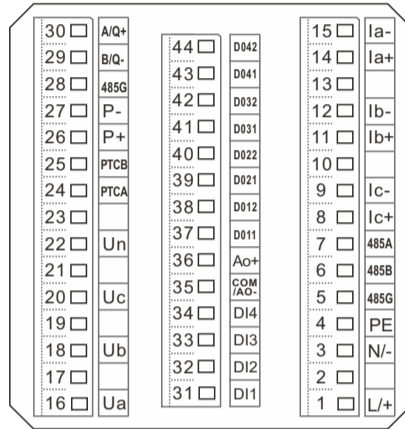

Index	Mark	Define	Index	Mark	Define	Index	Mark	Define
1	L/+	positive	16	Ua	Phase A voltage	31	D011	Switch input 1
2			17			32	D012	Switch input 2
3	N/-	negative	18	Ub	Phase B voltage	33	D013	Switch input 3
4	PE	ground	19			34	D014	Switch input 4
5	485G	Communication shielded ground	20	Uc	Phase C voltage	35	COM AO-	Common terminal of switch Negative analog output
6	485B	RS485 negative	21					
7	485A	RS485 positive	22	Un	Voltage neutral line	36	AO+	Positive analog output
8	Ic+	C-phase current into the line	23			37	D011	Relay output 1 positive
9	Ic-	C-phase current outlet	24	PTC A	Temperature input positive	38	D012	Relay output 1 negative
10			25	PTC B	Temperature input negative	39	D021	Relay output 2 positive
11	Ib+	B-phase current into the line	26	P+	Pulse output positive	40	D022	Relay output 2 negative
12	Ib-	B-phase current outlet	27	P-	Pulse output negative	41	D031	Relay output 3 positive
13			28	485G	Communication on shielded ground	42	D032	Relay output 3 negative
14	Ia+	A-phase current into the line	29	B/Q-	RS485 negative	43	D041	Relay output 4 positive
15	Ia-	A-phase current outlet	30	A/Q+	RS485 positive	44	D042	Relay output 4 negative

Note: 5,6,7 terminal configured as a standard RS485, terminals 28, 29, 30 are backup RS485.

**2.3 Typical wiring**

KPM73 provides two connection modes of star system and angle system. The common connection mode is as follows

**2.31 Star system wiring mode (for 400V/690V and above systems)**

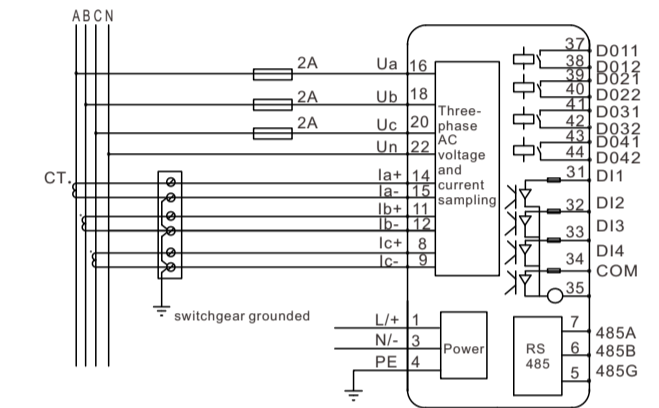

Quad-line star system: direct wiring without voltage transformer (PT) (device set to 3Ln3Ct)

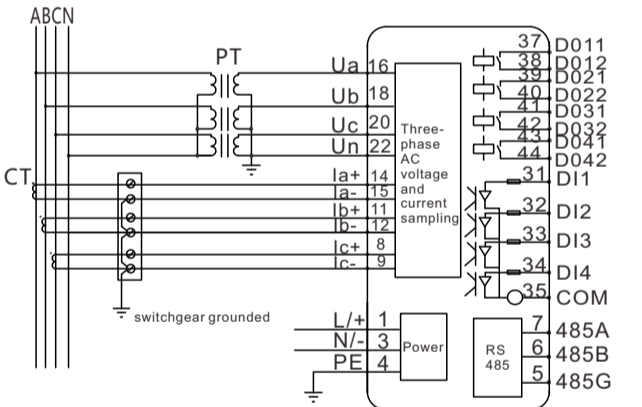

Quad-line star system: Uses 3 voltage transformers (PTs) (device set to 3Ln3Ct)

**2.32 Angle System Wiring Mode**

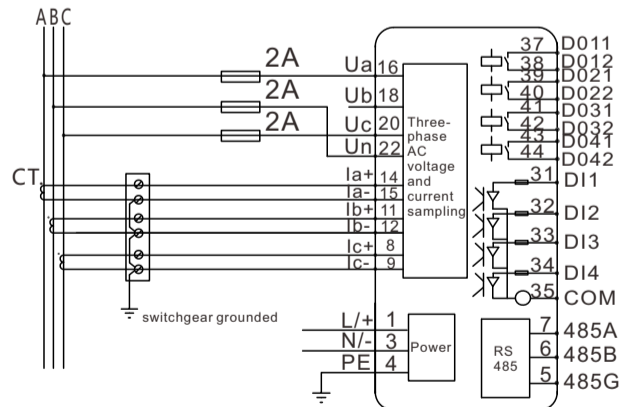

Angle system: no voltage transformer (PT), 3 current transformers (CT) (Device is set to 2LL3Ct)

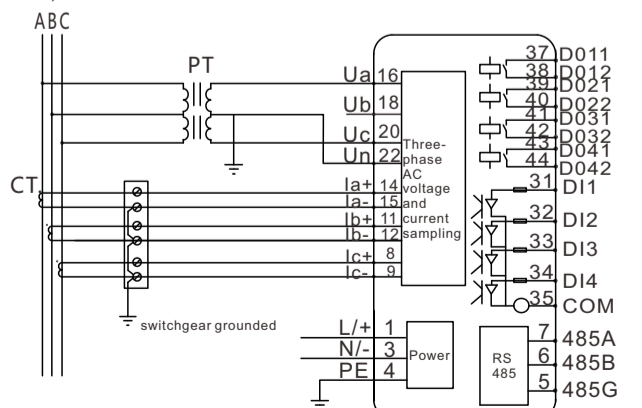

Angle system: use 2 voltage transformers (PT), 3 current transformers (CT) (Device is set to 2LL3Ct)

**3. Function Description**

**3.1 Power symbols**

KPM73 provides bidirectional power calculations with power and power factor polarities such as following fig showed:

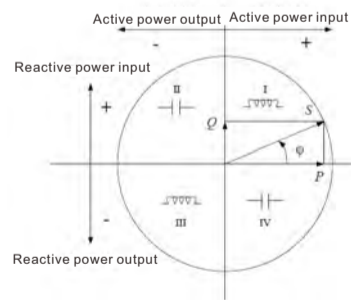

**3.2 Energy measurement**

KPM73 records bidirectional active and reactive energy, the sum of positive and negative bidirectional energy, and positive and negative net energy, active and reactive energy and value of this month, last month and last month. PUMG730 also provides multiple rates of electricity, peak four rates, can be set up to 8 hours in 24 hours a day, the time setting step is half an hour, you can record the peak Pinggu four rates total active/reactive energy, records The four rates are active/reactive energy this month, last month, and the month before last month.

**3.3 Demand**

Power systems often charge fees based on the user's power consumption (in the form of active energy) and the peak power level (in the form of active power). Demand is the average power over a certain time interval. KPM73 uses common slip demand algorithm to calculate demand.

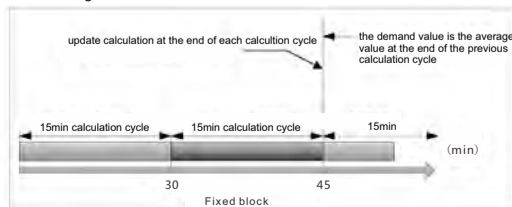

Slip time: Recursively measure the time interval of maximum demand, which can be selected in 1. 2. 3. 5. 10. 15. 30mi.  
Demand cycle: Setting range 1~15 slip times.  
Maximum Demand: Maximum Demand since Operation

**3.4 Switch input**

KPM73 provides 4 digital input channels for detecting status information such as circuit breaker position signal and contact-breaker position signal. DC24V power supply is provided inside the equipment. When switching input function is required, passive contact signal is externally connected. When the external contact is closed, the corresponding digital input status is also turned on.

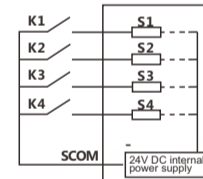

**3.5 Relay output**

KPM73 provides two kinds of relay action modes. The user should identify whether the relay is in remote control or over-limit alarm control. In different control modes, the relays operate in different ways.

**Remote control:**

The relay is controlled by commands from the PC or PLC via communication.

**Over limit alarm control:**

The relay is controlled by an electrical parameter inside the meter as a response to a set point control alarm condition.

The two relays operate as follows:

**Remote control:**

The relay closes by accepting a PC or PLC command. The relay status will remain until the PC or PLC issues a release command or the meter loses power.

**Over limit alarm control:**

When the trigger relay's alarm signal is generated, the relay operates. The relay is not released until all the alarm conditions for the trigger relay have disappeared or the meter has lost power. If the meter resumes power and the alarm condition still exists, the relay will act again.

**3.6 Pulse**

KPM73 provides active / reactive energy metering, 1 active energy pulse output, and adopts the optocoupler electrode open circuit output. The method of energy accuracy inspection refers to the national measurement protocol: Pulse error comparison method of standard table.

Electrical characteristics: Open collector voltage VCC≤48V, current Iz ≤50mA;

Pulse constant: 3200imp/kWh. It means when the meter accumulated 1kWh, the pulse output number is 3200. It is emphasized that 1kWh is the secondary side of the electric energy data. In the case of PT and CT, the relative N pulse data corresponds to the primary side energy is N ÷ 3200 × voltage transformation ratio × current transformation ratio (kWh)

**Application examples:**

The external pulse counting device, assumes that the number of pulses collected during a period of length T is N, and the instrument input is: 10kV/100V, 400A/5A, then the instrument energy accumulation during this time period is N ÷ 3200 × 100 × 80 kWh.

**3.7 Analog output**

Analog output 4mA corresponds to the lower limit of the range, 20mA corresponds to the upper range. When the range is exceeded, the transmission current increases linearly. The maximum effective output is 120% of the range, the maximum output current is 24mA, and the maximum load resistance is 400 ohms. The transmission curve is as follows

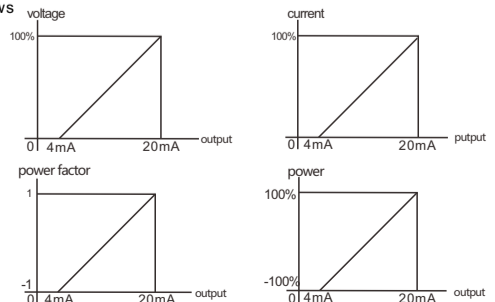

Explanation:  $P=(P_x-12) \times P_e \times CT \times PT/8$ ,  $P_x$  is the actual analog measured value, the unit is mA;

$P_e$  is the corresponding rated power, unit W,  $P_e$  value varies under different voltage levels, as follows:

220V/5A:  $P_e=3300W$  220V/1A:  $P_e=660W$   
100V/5A:  $P_e=1500W$  100V/1A:  $P_e=600W$

Note: When transmitting single-phase power,  $P_e = \text{rated voltage} \times \text{rated current}$ .

#### 4. Operating instructions

##### 4.1. Interface display

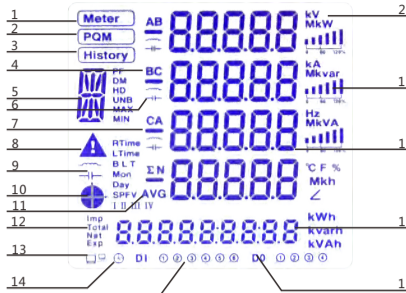

index	Display content	Detailed Description
1	Real-time data	contain basic electrical parameters, total power data, time, etc., contain demand, harmonics, voltage and current imbalance and so on.
2	Power Quality	
3	Historical data	Contains Multi-rate electric energy freeze data, daily freeze data, maximum and minimum value, etc.
4	Phase sequence indication	Indicated A, B, C-phase value, AB, BC, CA three-line value and Σ three-phase sum, such as three-phase total active power, total reactive power, total apparent power and so on, N represents zero line
5	Measurement data type	Identifies the parameter name displayed in the current measurement data display area in alphabetical form : Voltage 'U' Current is 'I' Active power 'P' Reactive power 'Q' Apparent power 'S' Power factor 'PF' Frequency 'F' Demand 'DM' Harmonic 'HD' Unbalance 'UNB' Maximum 'Max' Minimum 'Min', Temperature 'T' Meter operation time 'RTime' Load time 'LTime' Two months ago 'B Mon' Last month 'L Mon' This month 'M Mon' Yesterday 'Y Day' Today is 'T Day' The day before yesterday 'B Day' Peak Pinggu 'FPSV' Inductance symbol light: Indicates that it is an inductive load at this time, now, Q>0;
6	Each phase of the load nature indication	Capacitance symbol light: Indicates that it is a capacitance load at this time, now, Q<0;
7	Negative sign	Display when the measured data is negative
8	Alarm	Display when there is alarm signal
9	Total load property indication	Inductance symbol light: Indicates inductive load at this time, ΣQ>0; Capacitance symbol light: Indicates capacitive load at this time, ΣQ<0;
10	Load quadrant indication	The quadrant of the system power is displayed in quadrant diagrams. The first quadrant ΣP>0 and ΣQ>0, the second quadrant ΣP<0 and ΣQ>0, the third quadrant ΣP<0 and ΣQ<0, the fourth quadrant ΣP>0 and ΣQ<0.
11	average value	Data show average
12	Electrical type indication	Imp : Forward electrical metric ; Exp : reverse electric metric ; Total : Absolute value , the sum of the absolute values of the forward electrical and reverse electrical metric ; Net : net electrical degrees , The absolute value of the difference between Forward electrical metric and reverse electric metric.
13	Communication indication	If two small computers sign are all faded, it means there is no communication message; two small computers sign all show means the communication transceiver is proper functioning.
14	Clock indication	When this sign light, it indicates area 17 displays time data.
15	Switch input status	When there is a digital display, it indicates that the corresponding loop switch is closed.
16	Relay output status	When there is a digital display, it indicates that the corresponding loop relay is closed.
17	Power and time area	Display a variety of electrical measurement data, real-time clock, parameter settings, etc.
18	Measurement data display area	Display the main measurement data: voltage, current, power, power factor, frequency, temperature, harmonic data, demand, maximum, minimum, parameter setting data, etc.
19	Each phase load histogram	Load : Load size display ; Directly indicate the percentage of the load current relative to the rated current in the form of a histogram.
20	Electrical parameter unit symbol	voltage : V , kV, Current : A , kA, Activepower : W , kW , MW, Reactive power, kvar, Mvar, Apparent power : VA , kVA , MVA, Frequency : Hz, Active electricity kWh, Reactive electricity kvarh ;

##### 5:Current imbalance rate

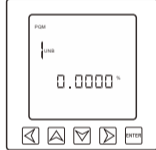

In the harmonic display interface, when "HD" is on, you can use the down key or up key to see the three-phase voltage and current harmonic total distortion rate and 2 ~ 31 harmonic content, the 32~51 harmonic content are read by the background. The upper left corner shows "U", for this parameter indicates a three-phase harmonic voltage, when display "I", for this parameter indicates a three-phase harmonic current, the first three lines show the total harmonic distortion and fractional harmonic content, the fourth line represents the current harmonic data type, the total harmonic distortion is displayed when "THd" is displayed, when "HR" is displayed, the data indicates the fractional harmonic content, 2 ~ 31 corresponds number of harmonics.

In "History" interface, press [ ] to enter daily freezing data display interface, then continuously press [ ] down or [ ] up turn to display the electrical parameter freezing data for today, yesterday and the previous day every 2 hours. The "T" "Day" light indicates today's data, "L" "Day" light indicates yesterday's data, and "B" "Day" light indicates the previous day's data.

In the maximum and minimum value query display interface, press the [ ] down button or use the [ ] button to rotate display the screen as shown below. At the same time, when the data is the maximum value, the character "MAX" is displayed on the left side, and when the data is the minimum value, the character "MIN" is displayed on the left side.

##### 4.3 Parameter setting

In parameter measurement interface, press ENTER key to enter the password input interface, the default password is 6666. Press the ENTER key again for confirmation after the password input. If input action is correct, the system will enter the parameter setting interface. If the input is wrong, it will return to the parameter measurement display interface.

In parameter measurement interface, Press [ ] UP key or [ ] DOWN key to switch the modifying parameters. Press the 'ENTER' key to enter the parameter value modify state, and accompanied with flashing for modification of the characters. After the setting is completed, press the 'ENTER' key to confirm the parameters changing. Then you can modify the next parameter, or you can also press [ ] button to exit the parameters modifying state, return to the measurement interface. When the user has no operation in 60 seconds in the parameters modifying state, the system will automatically return to the electrical parameter measurement display interface.

1:Wiring method SYSS	2:Rated voltage Un	3:4:Rated current Pt_U In	4:Voltage Ratio_U
5:Current Ratio CL1	6:Meter AdrESS Adr	7:Baud rate bAUd bAUd	8:Data format dATA
9:Backlight time BLt	10:Demand sliding window time dnnnd	11:Transmitting An	12:Date dATE

#### 5.2 Operation display

There are five touch buttons on the front panel, the five keys are marked as key left [ ], key up [ ], key down [ ], right key [ ], key enter [ ]. Through the operation of five keys can be achieved in different measurement data display and parameter settings.



Buttonname	Functional description
Left key	Switch the three major functions display interface: "Meter", "PQM", "History"; in the parameter setting state as "return" key.
Up key Down key	In different function display interface, press the up or down key to cycle through all the parameters of present function. In the parameter setting mode , press "up" to increase the value of the modified bit in the parameter setting state. Press "down" to decrease the value of the modified bit.
Right key	During "Meter" display, press this key to cycle the energy data; In the "PQM" power quality display, pressing this button cycles display demand, the harmonics, voltage and current imbalance. Under "History" display, press this button to show the Multi-rate electric energy freeze data, daily freeze data, maximum minimum value. In parameter setting state, it is used to move the bits to be modified. Confirm to enter the programming state; in the parameter setting state, it is used to enter the menu, programming parameters and confirmation.
ENTER	

Measurement display menu structure as follows

Press left button, the screen shows cyclically as following FIGS,

1:Meter measurement interface	2:PQM Power quality measurement interface	3:History data interface
4:Three phase voltage average voltage	5:Three phase and total reactive power	6:Three phase and total apparent power
7:Three phase current zero-line current	8:Three phase and total power factor	9:Frequency
10:Line voltage Average voltage	11:TEMP	

12:Time TIME	13:Electric energy clear Enclr	14:Max / min value clear CLR	15:Password PASS
16:Pulse constant Pulse Const	17:Instantaneous starting current threshold IST	18:Version information VER	

19:Time TIME	20:Electric energy clear Enclr	21:Max / min value clear CLR	22:Password PASS
23:Pulse constant Pulse Const	24:Instantaneous starting current threshold IST	25:Version information VER	

26:Time TIME	27:Electric energy clear Enclr	28:Max / min value clear CLR	29:Password PASS
30:Pulse constant Pulse Const	31:Instantaneous starting current threshold IST	32:Version information VER	

Note: The display serial number is different accord to different the setting

##### Factory default value:

Parameter	Display	Default	Implication
Password protection	PASS	6666	Used to protect non-staff to modify instrument
Wiring method	SYSS	3Ln3CT	Three-phase four-wire system , 2LL2CT and 2LL3CT are Three-phase three-wire system
Rated voltage	Un	220	Could be set as 100, 220, 400
Rated current	In	5	Could be set as 1, 5, 10
Voltage ratio	Pt_U	1	Voltage transformer ratio : 1~9999
Current ratio	CL1	1	Current transformer ratio : 1~9999
Communication address	Adr	1	The address of the meter when the network is in communication, 1~247
Baud rate	baud	9600	Communication Baud rate address 1200~38400
Data format	dATA	81N	Data frame format : 8 data bits, a parity bit and one stop bit units : minute ; if set to 0, the backlight will never go out; set to other values, the light will go off after the setting time delay after the last key.
Backlight lighting time	BLt	1	
Transmitting	An	Ua	3Ln3CT can be transmitted to the project Ua, Ub, Ucl, Ib, Ic, Uab, Ubc, Uca, Pa, Pb, Pc, P, Qa, Qb, Qc, Q, Sa, Sb, Sc, S, Pfa, Pfb, Pfc, PF, F; 2LL CT and 2LL3CT can be transmitted to the project: Ia, Ib, Ic, Uab, Ubc, Uca, P, Q, S, PF, F.
System date	dATE	Current date	Such as : 2012.05.08
System time	tinE	Current time	Such as : 09:35:20
Clear Electric energy	cLEr	Enclr	Cleared
Clear Max Min value	CLr	MaxMin	Used to clear the maximum and minimum value.
Pulse constant	Pulse	Const	3200
Startup current	IST	10	Setting range 1~9999mA
Firmware version	VER		The firmware program version and date of the device

#### 5. Communication

KPM73 multifunction meter provides MODBUS-RTU communication protocol, 1 start bit, 8 data bits, 1/0 parity, 1/2 stop bits. Each byte length is 11 bits. Supported baud rates: 1200, 2400, 4800, 9600, 19200, 38400. Factory default communication parameters: 9600, no parity, 1 stop bit. RTU mode format for each byte: 1 start bit + 8 data bits + 1 parity bit + 1 stop bit. The format of the data frame is as follows: Address field + Command field + Data field + CRC check area. Note: The minimum frame communication interval is 100ms.

DEC	HEX	definition	Operation description
01	0x01	Read relay output	Read one or more relay outputs
02	0x02	Read switch input	Read one or more switch input
03	0x03	Read register data	Read the value of one or more registers
05	0x05	Write a single relay output	Control all the way to close or disconnect the relay
16	0x10	Write multiple registers	Write multiple register data at a time

In the "Meter" interface, right-click to enter the electric energy and time query interface, press the right button continuously to display the interface as the following FIG shown. When the time and date are displayed, the clock pattern is displayed in the lower left corner of the screen. When the energy accumulated more than 99999999.9, the hexadecimal representation of the floating point number of the energy accumulated value is displayed, F indicates that the maximum display value is exceeded.

1:Import active energy	2:Export active energy	3:Absolute active energy	4:Net active energy
5:Import reactive energy	6:Export reactive energy	7:Absolute reactive energy	8:Net reactive energy
9:Phase A Import active energy	10:Phase A Export active energy	11:Phase A Import reactive energy	12:Phase A Import reactive energy
13:Phase B Import active energy	14:Phase B Export active energy	15:Phase B Import reactive energy	16:Phase B Import reactive energy
17:Phase C Import active energy	18:Phase C Export active energy	19:Phase C Import reactive energy	20:Phase C Import reactive energy
21:Time	22:Date	23:Operation time	24:Load time

In the "PQM" interface, press right key, the screen will display electric energy quality cyclically , as shown below:

1:Power demand	2:Voltage harmonics	3:Current harmonic	4:Voltage imbalance rate
----------------	---------------------	--------------------	--------------------------

#### 6. Common malfunction Analysis

- Nothing is displayed after the unit is powered on
- Check if the supply voltage and other wiring are correct, also the supply voltage should be within the operating range
- Turn off the device and the host computer, and then reboot
- The device is not working properly after power on
- Turn off the device and the host computer, and then reboot
- Voltage or current readings incorrect
- Check if the wiring mode setting matches the actual wiring mode
- Check whether the voltage transformer (PT) and current transformer (CT) ratio are set correctly
- Check if GND is grounded properly.
- Check if the shield is grounded
- Check if the voltage transformer (PT) and current transformer (CT) are intact
- The power or power factor reading is incorrect, but the voltage and current readings are correct
- Compare the voltage and current input of the actual wiring and wiring diagram, and check if the phase relationship is correct.
- RS-485 communication is not working properly
- Check whether the communication baud rate, ID and communication protocol settings of the host computer are consistent with the meter
- Please check the data bits, stop bits, parity settings and the host computer is consistent
- Check if the RS-232 / RS-485 converter is working properly
- Check if there are the problems in the entire communications network lines (Such as short circuit, open circuit, grounding, if the shield is properly grounded at one end, etc.)
- Turn off the device and the host computer, and then reboot
- If the communication line is longer, it is recommended to parallel connect a 100 ~200Ω matching resistors at the end of the communication line.

Note: If there are any unsolved problems, please contact our company's after-sales service department.

#### 7 Contact Details

**Henan Compere Smart Technology CO., LTD.**  
Telephone:+86-371-86181681  
Fax:+86-371-67890037  
Web:www.compere-power.com  
Address:Unit 1, Building 38, Liandong U Valley, No. 352 Lianhua Street, High-tech Zone, Zhengzhou, China

The final interpretation of this manual is owned by Henan Compere Smart Technology Co.,Ltd.